

# MC 3C - MC 4M

## Instructions for use



**heupel** Reinigungstechnik GmbH

Gottlieb Daimler Str. 6  
88214 Ravensburg

email: [info@heupel-gmbh.de](mailto:info@heupel-gmbh.de)  
[www.heupel-gmbh.de](http://www.heupel-gmbh.de)

Tel: (049) 0751 - 35905-3  
Fax: (049) 0751 - 35905-59

**Shop: [www.heupel-shop.de](http://www.heupel-shop.de)**

Heupel - Reinigungstechnik - Beratung, Verkauf, Service, alles aus einer Hand.

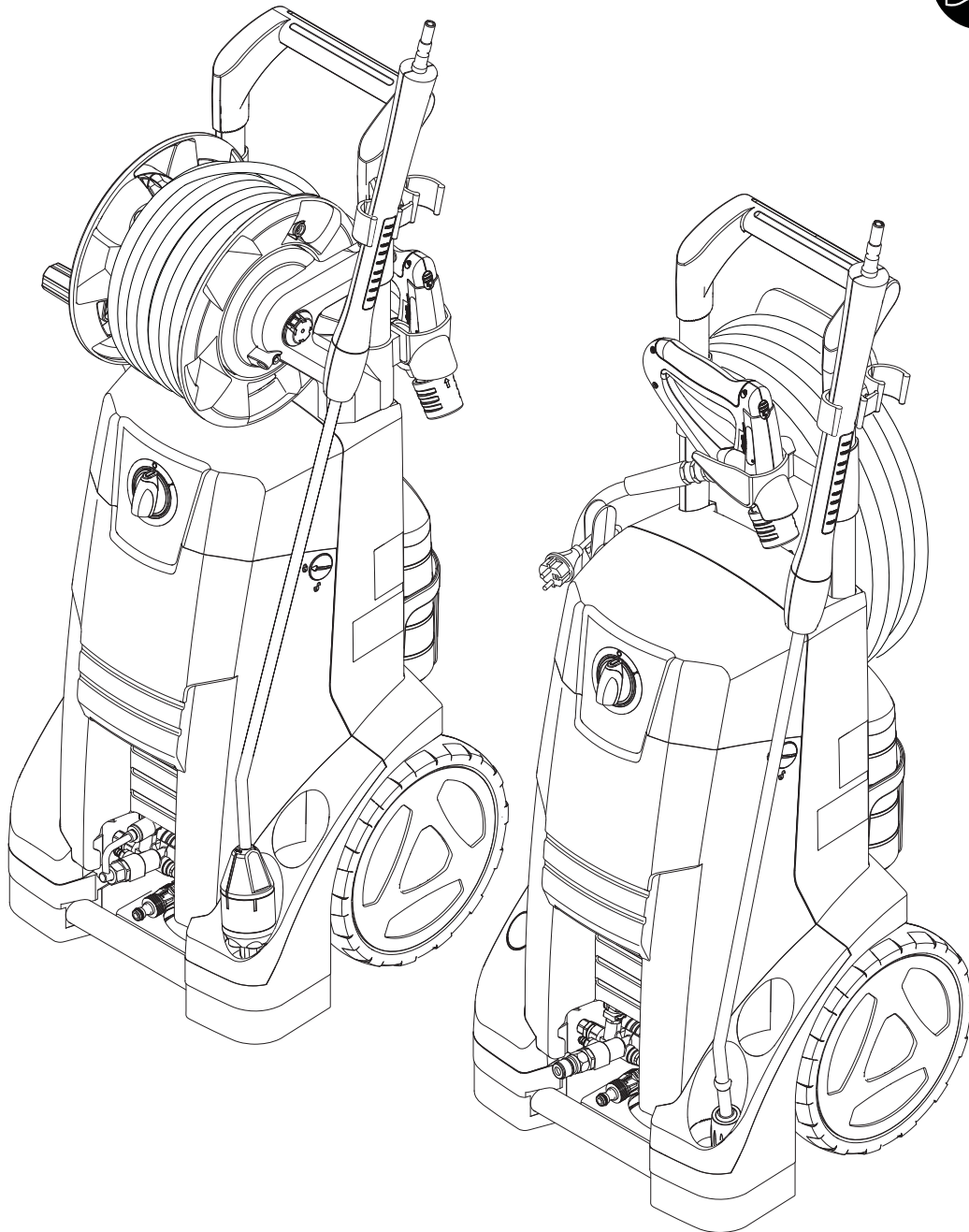

<b>EN</b>	Operating instructions .....	9
<b>DE</b>	Bedienungsanweisungen .....	11
<b>FR</b>	Instructions de fonctionnement .....	14
<b>NL</b>	Gebruiksaanwijzingen .....	17
<b>IT</b>	Istruzioni per l'uso .....	20
<b>NO</b>	Bruksanvisning .....	23
<b>SV</b>	Bruksanvisning .....	26
<b>DA</b>	Betjeningsvejledning .....	28
<b>FI</b>	Käyttöohje .....	30
<b>ES</b>	Instrucciones de funcionamiento .....	33
<b>PT</b>	Instruções de Funcionamento .....	36
<b>EL</b>	Οδηγίες λειτουργίας .....	39
<b>TR</b>	Kullanma Talimatları .....	42
<b>SL</b>	Navodila za delovanje .....	46
<b>HR</b>	Upute za uporabu .....	49
<b>SK</b>	Návod na obsluhu .....	52
<b>CS</b>	Návod k obsluze .....	55
<b>PL</b>	Instrukcje dotyczące obsługi .....	58
<b>HU</b>	Használati útmutató .....	61
<b>RO</b>	Instrucțiuni de utilizare .....	64
<b>BG</b>	Указания за експлоатация .....	67
<b>RU</b>	Руководство по эксплуатации .....	70
<b>ET</b>	Tööjuhised .....	73
<b>LV</b>	Norādījumi par ekspluatāciju .....	75
<b>LT</b>	Naudojimo instrukcija .....	78
<b>JA</b>	作手順.....	81
<b>ZH</b>	操作说明 .....	84
<b>KO</b>	사용법.....	86
<b>TH</b>	คำแนะนำการใช้งาน.....	89
<b>MS</b>	Arahan Operasi.....	91

**MC 3C-XT/MC 4M-XT**

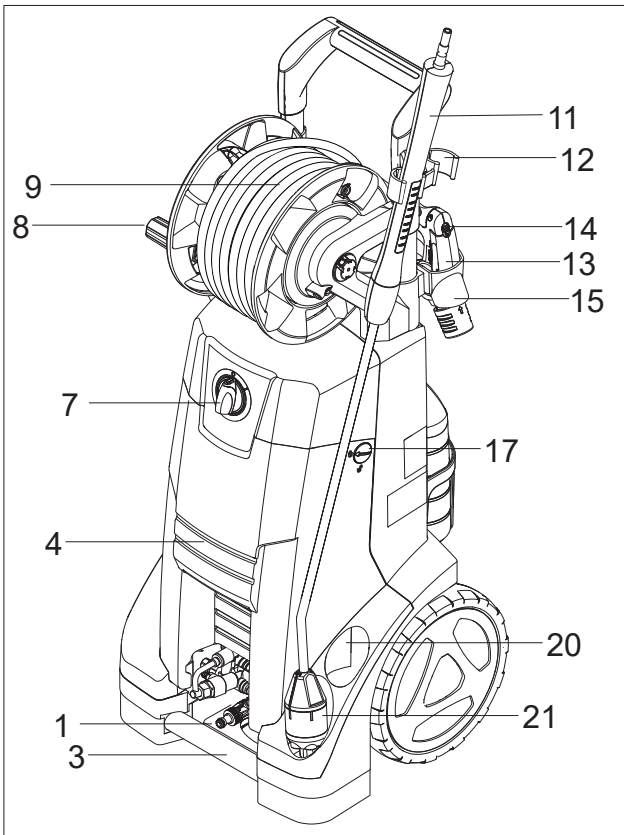

**MC 3C/MC 4M**

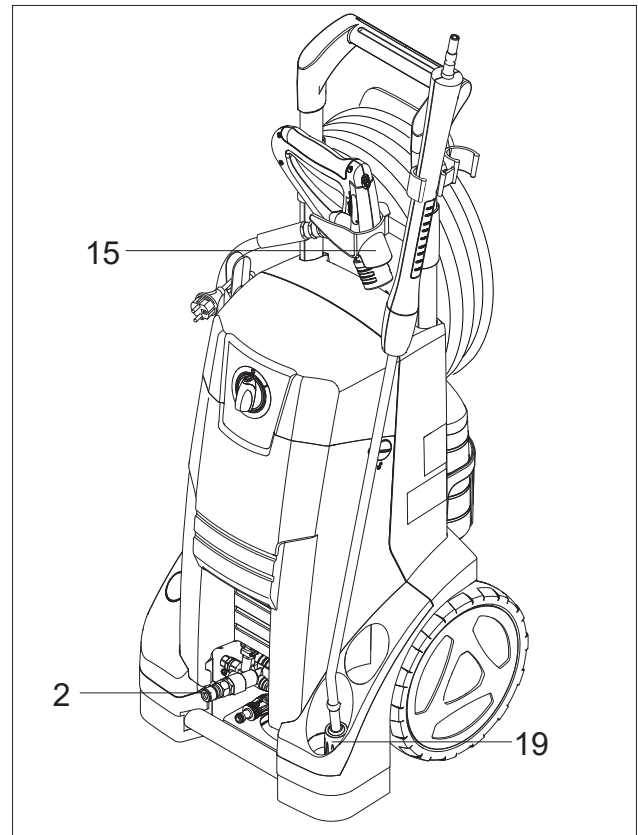

**MC 3C-XT/MC 4M-XT**

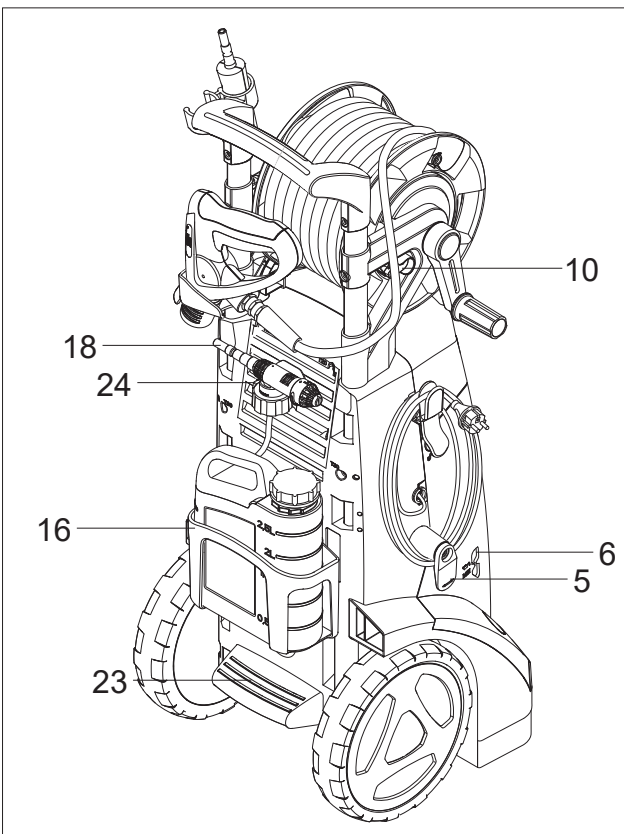

**MC 3C/MC 4M**

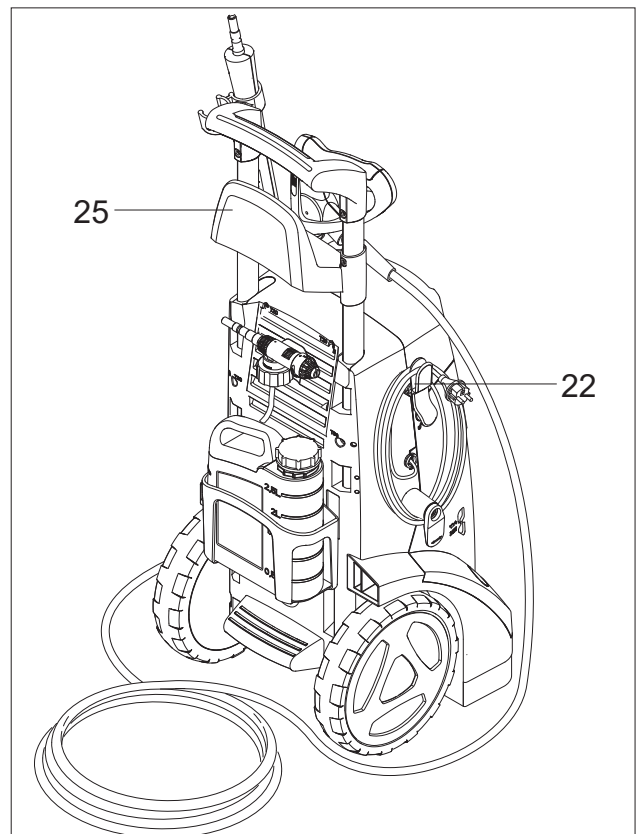

A - MC 3C-XT/MC 4M-XT

A - MC 3C/MC 4M

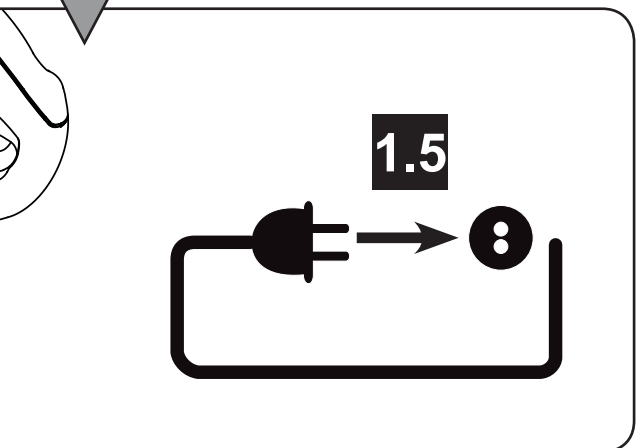
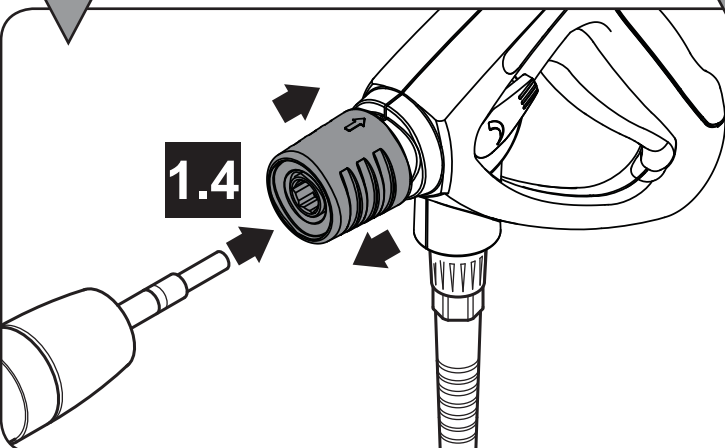
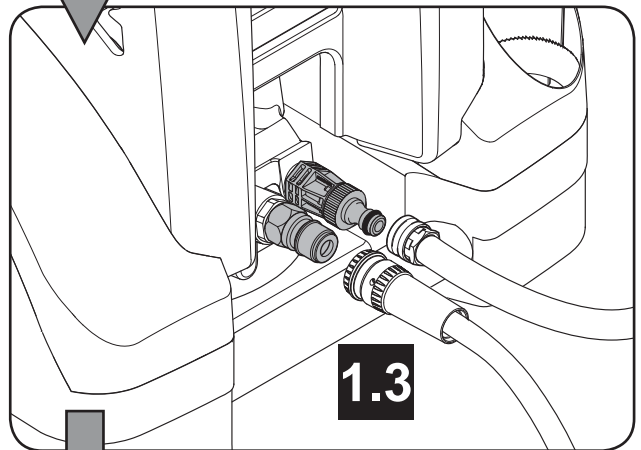
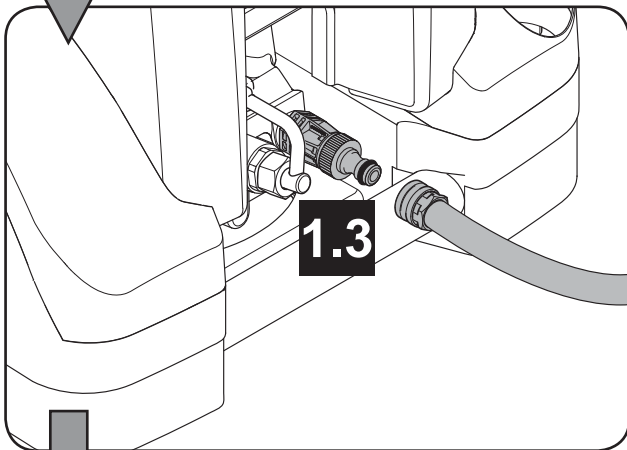
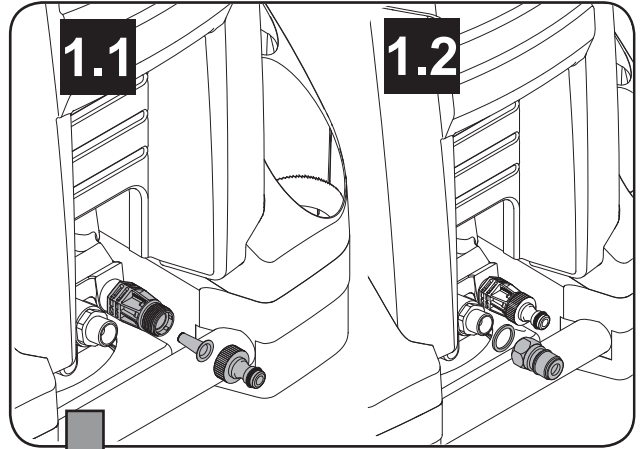
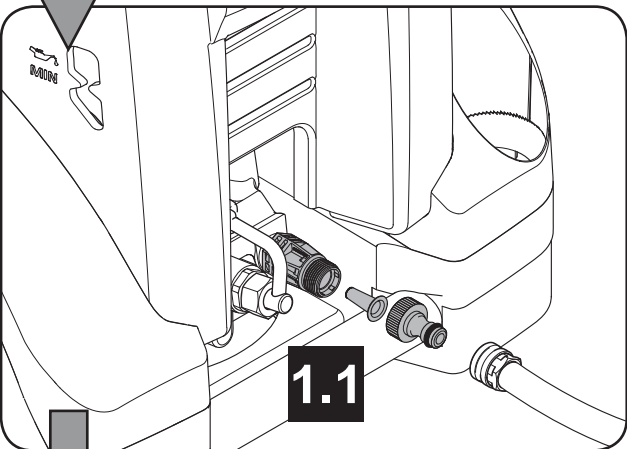
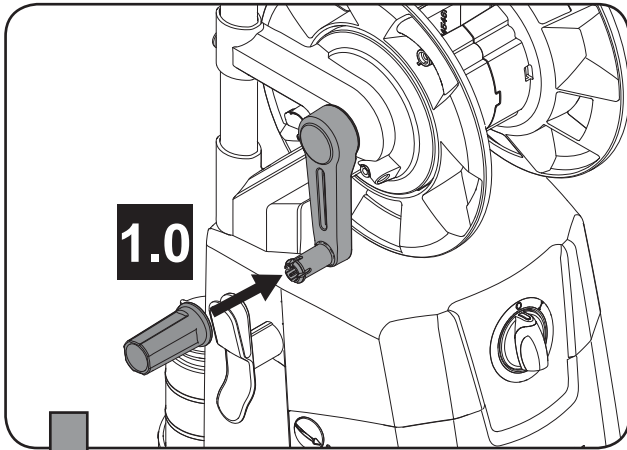

**B - MC 3C-XT/MC 4M-XT**

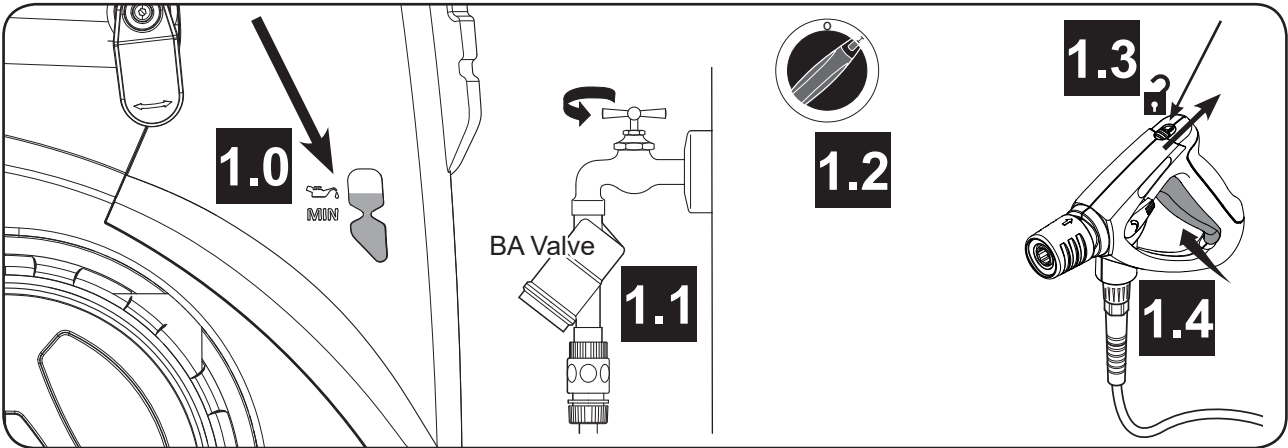

**B - MC 3C/MC 4M**

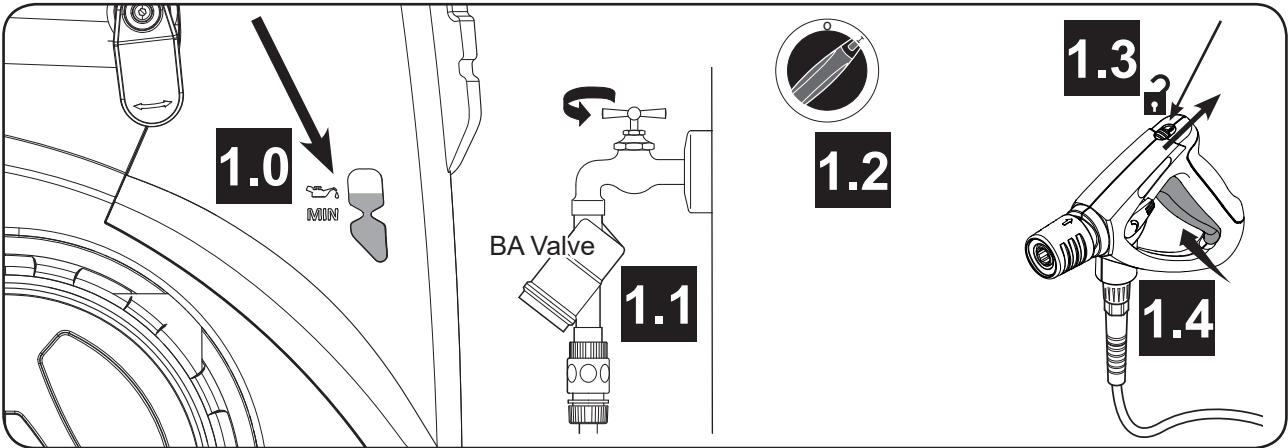

**C - MC 3C-XT/MC 4M-XT**

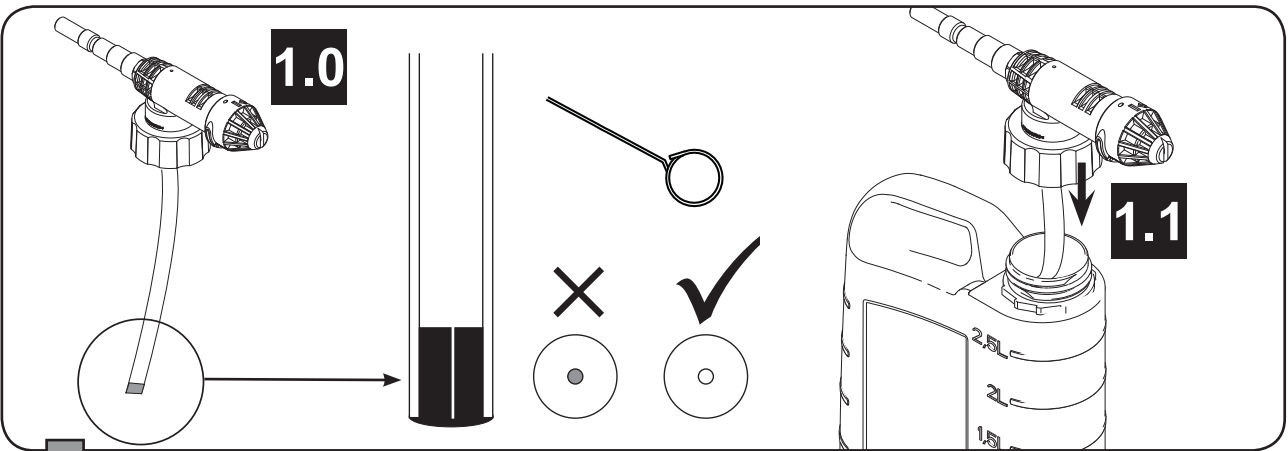

**C - MC 3C/MC 4M**

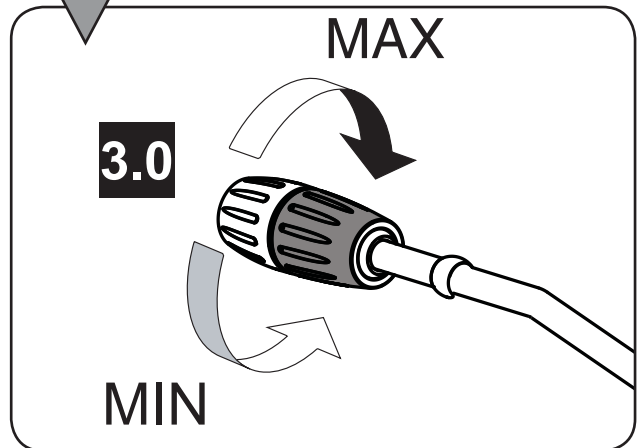
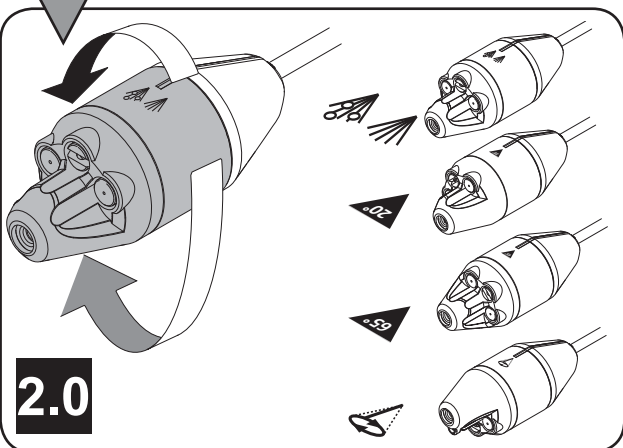
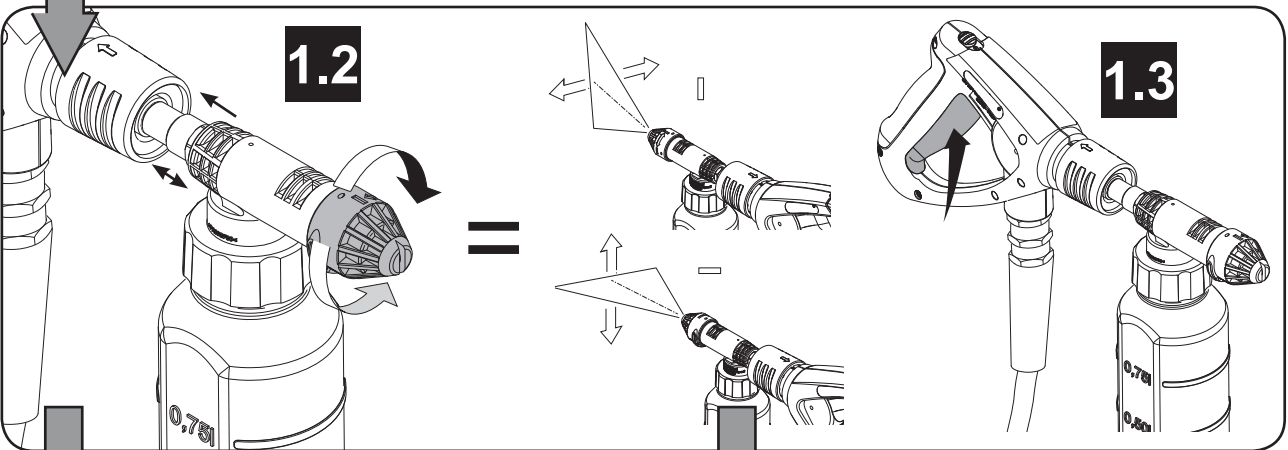
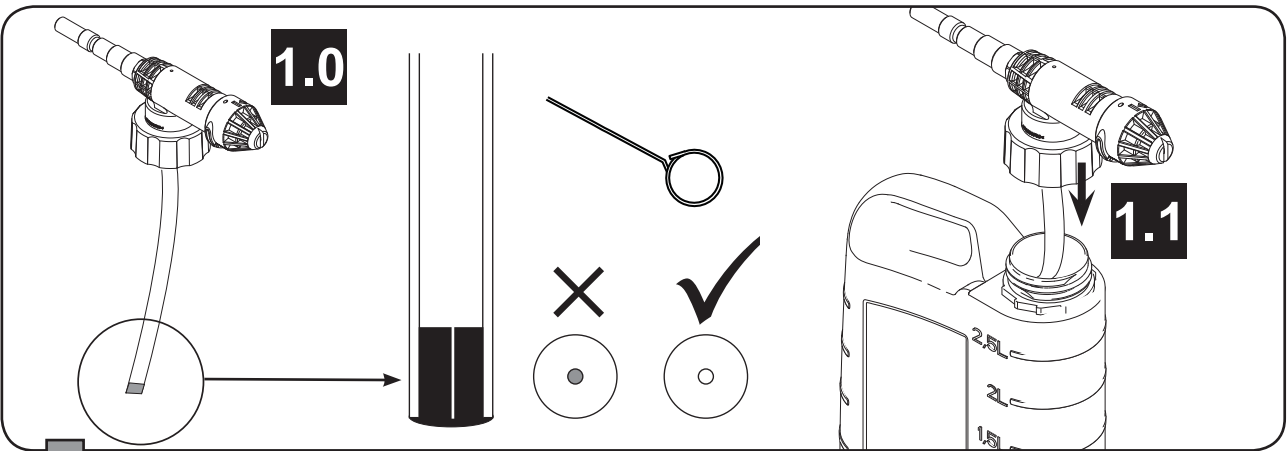

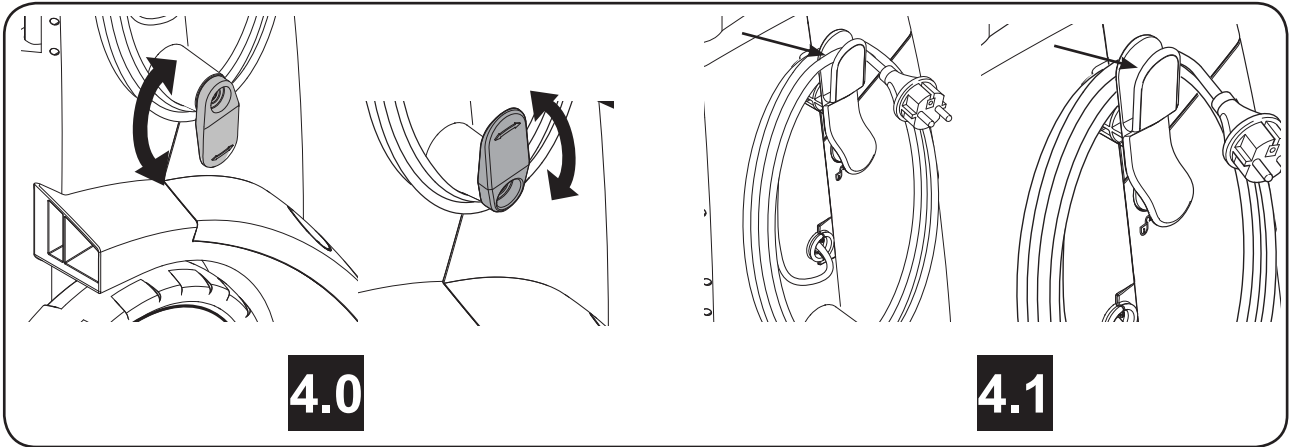

**4.0**

**4.1**

C - MC 3C-XT/MC 4M-XT

C - MC 3C/MC 4M

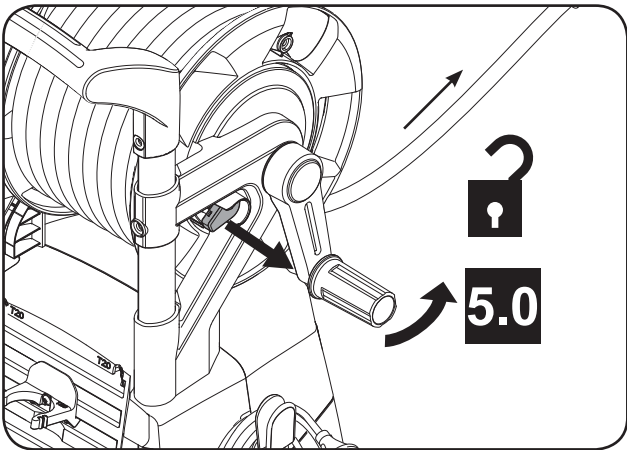

**5.0**

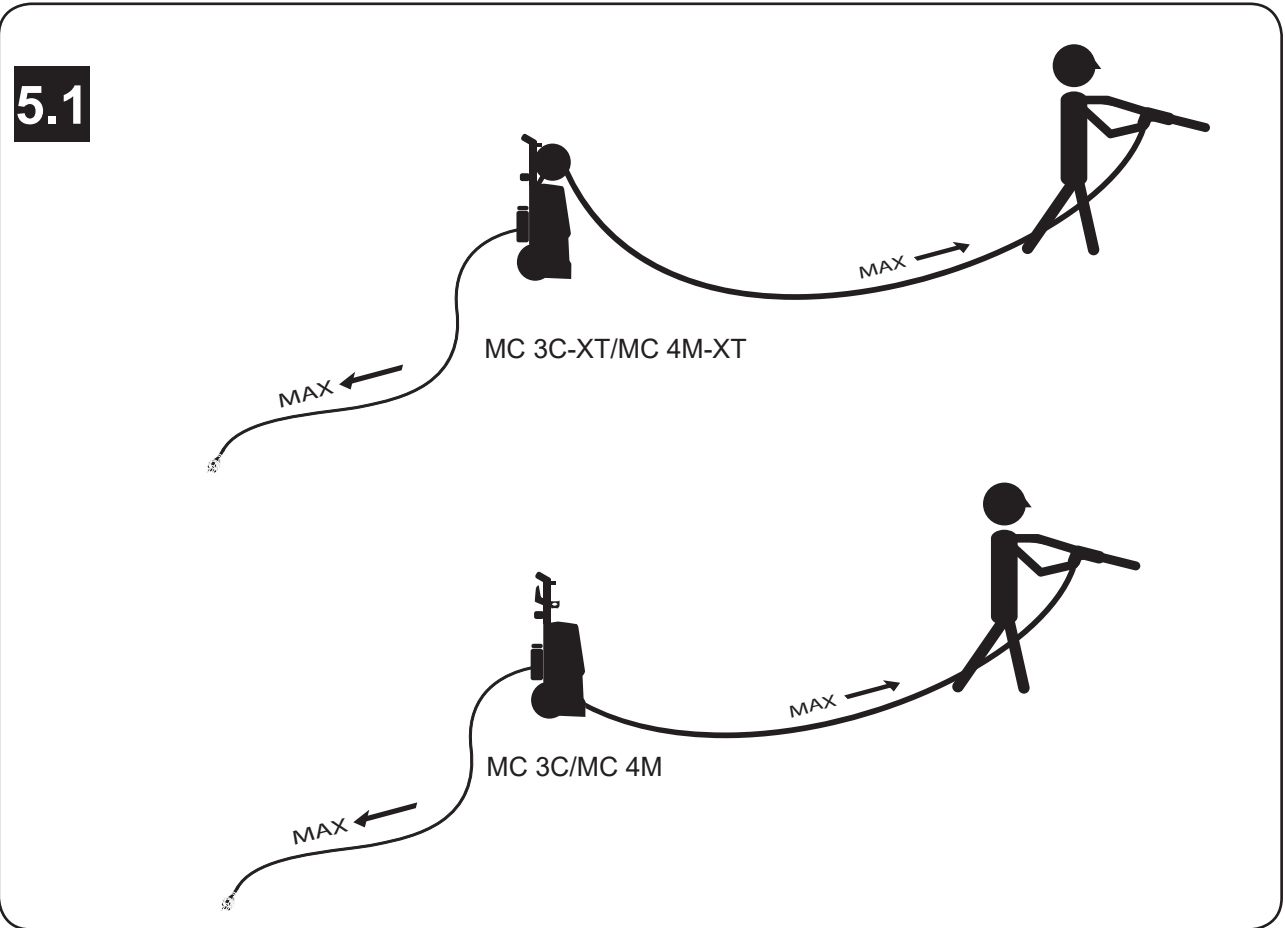

**5.1**

MC 3C-XT/MC 4M-XT

MC 3C/MC 4M

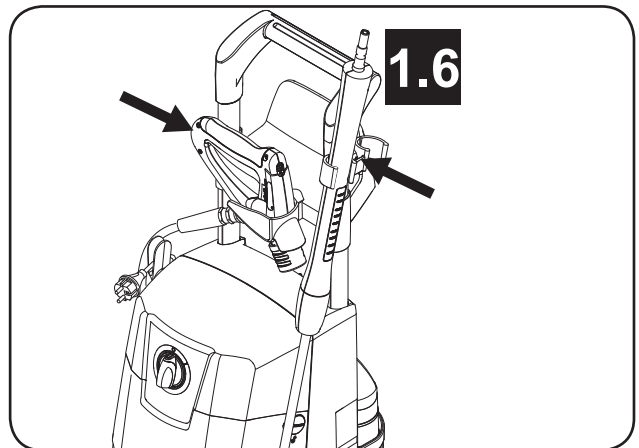
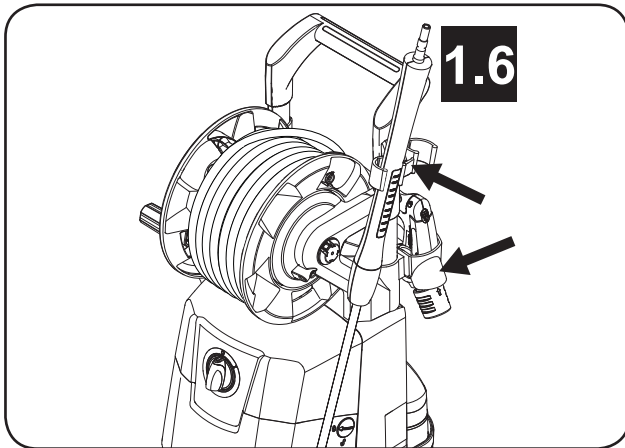
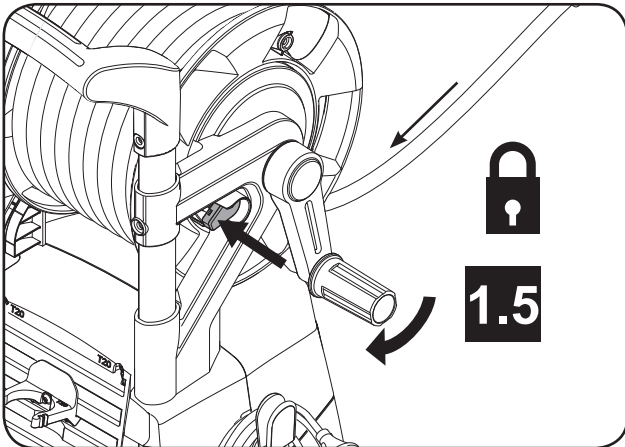
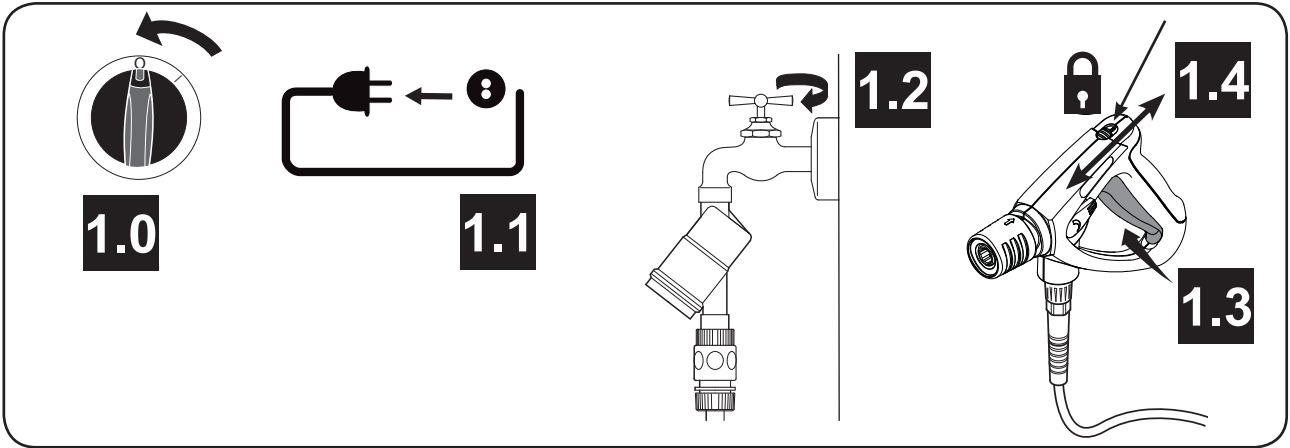

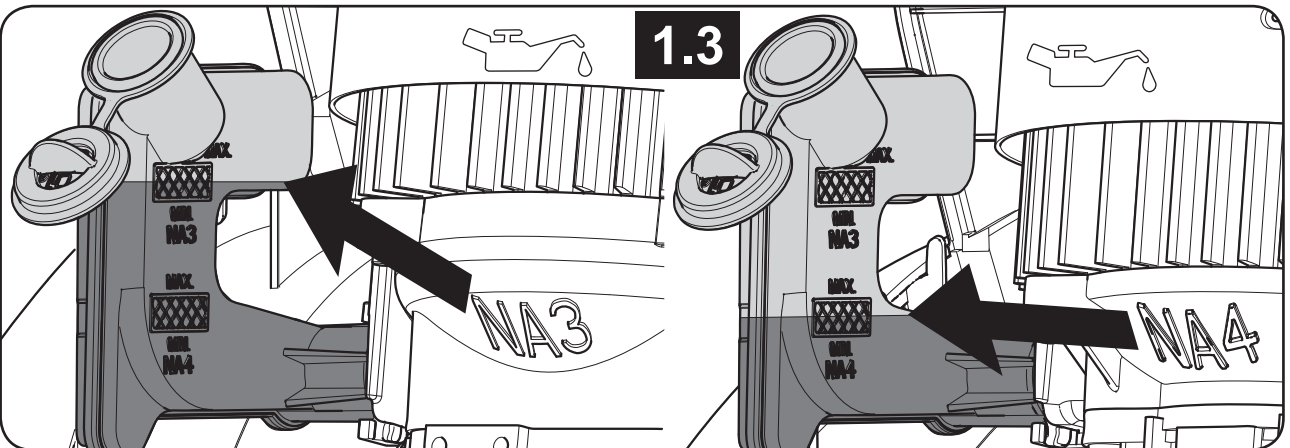
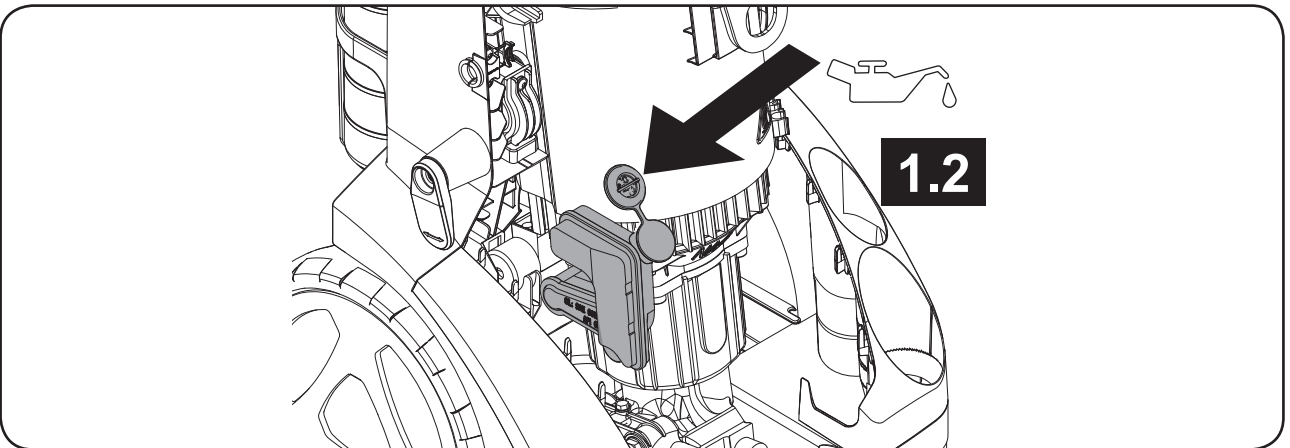
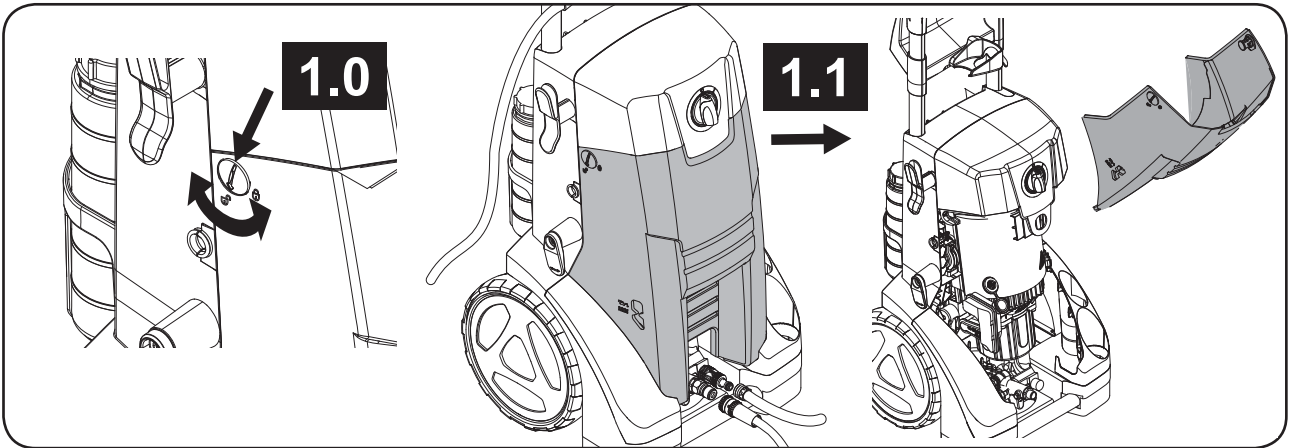



# Kurzanleitung

Dieser Hochdruckreiniger ist für den professionellen Einsatz vor allem in den folgenden Anwendungsbereichen bestimmt:

Boden/Wand, Pkw/Lkw, Gebäude/Konstruktionen, Container/Behälter und Handwerk.

## Illustrierte Kurzanleitung

Die illustrierte Kurzanleitung soll Sie bei Inbetriebnahme, Benutzung und Lagerung des Geräts unterstützen. Die Anleitung ist in fünf Abschnitte gegliedert.

### A

#### Vorbereitung

#### LESEN SIE BITTE VOR DER BENUTZUNG DIE SICHERHEITSHINWEISE!

##### Bedienelemente:

1. Wasseranschluss
2. Anschluss für Hochdruckschlauch
3. Hebegriff
4. Gehäuse
5. Drehbarer Kabelhaken
6. Ölstandanzeige
7. Ein-/Aus-Schalter
8. Griff Schlauchtrommel \*)
9. Schlauchtrommel \*)
10. Sperre Schlauchtrommel \*)
11. Sprührohr
12. Halterung für Sprührohr
13. Ergo 2000 Sprühgriff
14. Kindersicherung
15. Halterung für Sprührohr \*)
16. Halterung mit 2½ l Kanister \*)
17. Gehäuseverschluss
18. Schaumdüse \*)
19. FlexoPower Sprührohr \*)
20. Vertiefung für Sprührohre
21. 4-in-1-Sprührohr \*)
22. Befestigung Kabelende
23. Fußbrett
24. Halterung für Schaumdüse/Kanisterdeckel \*)
25. Schlauchhaken \*)

##### Montage des Geräts:

- 1.0 Den Griff an der Schlauchtrommel anbringen
- 1.1 Filter und Gardenakupplung montieren
- 1.2 Dichtung und 3/8-Zoll-Anschluss an Hochdruckauslass montieren
- 1.3 Schläuche anschließen (Wasserzufluss- und Hochdruckschlauch)
- 1.4 Sprührohr einstecken
- 1.5 Zuleitungskabel an Stromnetz anschließen

### B

#### Einschalten des Geräts

- 1.0 Ölstand prüfen (siehe E1.2)
- 1.1 Wasserhahn öffnen

OBS: die Umgebungstemperatur muss zwischen 0°C und 40°C liegen. Die Maschinentemperatur darf nicht unter 0°C liegen.

- 1.2 Hochdruckreiniger einschalten
- 1.3 Kindersicherung am Sprühgriff öffnen
- 1.4 Sprühgriff betätigen

### C

#### Bedienung und Betrieb

##### Reinigungsmittel verwenden:

- 1.0 Das Loch des Saugbegrenzers der Schaumdüse überprüfen und ggf. reinigen
- 1.1 Schaumdüse auf Kanister aufschrauben
- 1.2 Den Sprühwinkel auf waagrecht/senkrecht einstellen
- 1.3 Sprühgriff betätigen

##### Auswahl der Düse bei 4-in-1-Sprührohr

##### (XT Modelle):

- 2.0 Durch Drehen des Sprühkopfs die gewünschte Düse auswählen

##### Druck des FlexoPower Sprührohrs einstellen (Standardmodelle):

- 3.0 Den blauen Teil des Sprühkopfes in Richtung Min. bzw. Max. drehen

##### Kabel abnehmen und aufrollen:

- 4.0 Zum Abnehmen des Kabels den Haken drehen/Aufrollen
- 4.1 Nach Benutzung das Kabelende am Haken einstecken

##### Abrollen der Schlauchtrommel:

- 5.0 Die Sperre der Schlauchtrommel lösen und den Schlauch herausziehen
- 5.1 Während der Benutzung MÜSSEN Kabel und Schlauch vollständig entrollt sein

### D

#### Nach Verwendung

- 1.0 Hochdruckreiniger ausschalten
- 1.1 Netzstecker abziehen und Kabel aufrollen
- 1.2 Wasserhahn schließen
- 1.3 Druck durch Betätigen des Sprühgriffs ablassen
- 1.4 Kindersicherung aktivieren
- 1.5 Schlauch aufrollen und Schlauch Sperre aktivieren
- 1.6 Sprührohr und -griff in die Halterungen legen

### E

#### Wartung

- 1.0 Das Gehäuse am Verschluss öffnen (dazu Münze oder Schraubendreher verwenden)
- 1.1 Gehäusedeckel abnehmen
- 1.2 Ölstand prüfen und ggf. Öl bis Max. auffüllen (SAE 80W-90)
- 1.3 Maximaler Ölstand bei Pumpentyp MC 3C (NA3) bzw. MC 4M (NA4)

## Problemlösungen MC 3C-MC 4M

Problem	Ursache	Maßnahme
Schwankender Druck	Luft im Einlassschlauch.	Den Schlauch vollständig mit Wasser füllen und erneut anschließen
	Unzureichende Wasserversorgung	Stopp! Dafür sorgen, dass ausreichender Wasserdruck vorhanden ist, der den Angaben der Pumpe (Q <sub>max</sub> ) entspricht
	Wasserfilter ist verstopft	Wasserfilter reinigen
	Hochdruckdüse ist verstopft/verschlissen	Die Düse reinigen oder austauschen
	Saughöhe wurde überschritten	Stopp! Dafür sorgen, dass die maximale Saughöhe eingehalten wird
Schaumdüse liefert keinen Schaum	Es wird ein nicht-schäumendes Reinigungsmittel verwendet	Nur Reinigungsmittel mit Schaumbildnern verwenden.
	Die Düse des Saugschlauchs ist verstopft oder mit ausgetrockneter Seife gefüllt	Den Saugbegrenzer reinigen, mit lauwarmem Wasser durchspülen
	Der Schaumschwamm in der Schaumdüse ist verstopft.	1 Die Schaumdüse mindestens 8 Stunden lang in warmem Wasser einweichen/abspülen 2 Oder das Vorderteil der Schaumdüse abnehmen und den Schaumschwamm abspülen oder austauschen
	Reinigungsbehälter ist leer	Reinigungsbehälter auffüllen
Der Motor startet nicht oder brummt beim Einschalten	Defekt im Stromkabel	Wenden Sie sich an einen Elektriker, um das Stromkabel austauschen zu lassen.
	Der Stecker ist nicht in der Steckdose	Stecker hineinstecken
	Netzstromsicherung wurde ausgelöst	Sicherung wieder einschalten
	Lose Verbindung zwischen Stecker und Kabel	Durch Elektriker Kabel reparieren/austauschen lassen
	Die Pumpe ist blockiert oder eingefroren	Stopp! Pumpe auftauen oder an Kundenservice wenden
	Die Thermosicherung wurde aktiviert	Stopp! Das Gerät mindestens 5 Minuten lang abkühlen lassen

## Wartungsplan

	Wöchentlich	Nach den ersten 50 Betriebsstunden	Alle 200 Betriebsstunden	Bei Bedarf
Wasserfilter reinigen	A1.1			A1.1
Ölstand prüfen/Öl nachfüllen	B1.0/E1.2			
Pumpenöl wechseln		Wenden Sie sich an Ihren Händler/den technischen Kundendienst	Wenden Sie sich an Ihren Händler/den technischen Kundendienst	

## Besondere Betriebsanleitung

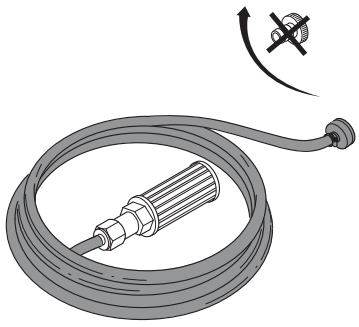
Selbst-ansaugen		<p>0: Den Hochdruckschlauch vom Gerät abnehmen.          1: Den Saugschlauch mit Wasser füllen und am Hochdruckreiniger anbringen (Art.-Nr. 6400000)          2: Den Saugschlauch mit einer Schlauchklemme am Pumpenanschluss befestigen.          3: Den Hauptschalter einige Sekunden lang auf „I“ stellen. Den Hauptschalter einige Male wiederholt ein- und ausschalten, bis Wasser aus der Pumpe kommt.          4: Hochdruckschlauch, Sprühgriff und Sprührohr wieder anbringen.          5: Den Hauptschalter auf „I“ stellen.          6: Den Sprühgriff entsperren und einige Male betätigen, bis Wasser ohne Luft austritt.</p>
-----------------	---	---

Für Saugfunktion benötigte Teile	Artikel-Nr.
1 x Schlauchdüse 20R 3/4"	61369
1 x Schlauch 3/4"	Max. 5 Meter Länge
1 x Schlauchklemme 3/4"	
1 x Sauffilter mit Fußventil	6400000

## Specifications

			MC 3C- 150/570 XT 230/1/50/13	MC 3C- 140/570 230/1/50/13	MC 3C- 150/660 230/1/50/16	MC 3C- 130/660 220/1/60/15	MC 3C- 150/660 XT 230/1/50/16	MC 3C- 160/770 400/3/50
1			UK 英国	UK 英国	EU 欧盟	exp 其他	EU 欧盟	EU 欧盟
2		V/ph/Hz	230/1/50	230/1/50	230/1/50	220/1/60	230/1/50	400/3/50
3		A	13	13	16	15	16	16
4		kW кВт	3,0	3,0	3,5	3,5	3,5	4,0
5		bar (MPa) Бар (МПа) 巴 (兆帕)	150 (15)	140 (14)	150 (15)	130 (13)	150 (15)	160 (16)
6		l/h л/час 升/小时	520	520	600	600	600	700
7		bar (MPa) Бар (МПа) 巴 (兆帕)	200 (20)	200 (20)	200 (20)	190 (19)	200 (20)	200 (20)
8		l/h	570	570	660	660	660	770
9		°C (°F)	60, >40 max. 1 h. (140, >104 max. 1 h.)					
10		bar (MPa) Бар (МПа) 巴 (兆帕)	10 (1)					
11		m 米	0,5					
12		mm 毫米	382x382x1017					
13		kg кг	38	35,7	35,7	35,7	38	35,7
14	 (IEC 60335-2-69)	dB(A)+/-2 дБ(A)+/-2	78	78	78	78	78	81
15	 (IEC 60335-2-69)	dB(A)+/-2 дБ(A)+/-2	91	91	91	91	91	94
16a	 (ISO 5349 a <sub>h</sub> ) 	m/s <sup>2</sup> 米/秒 <sup>2</sup>	<2,5	<2,5	<2,5	<2,5	<2,5	<2,5
16b	 (ISO 5349 a <sub>h</sub> ) 	m/s <sup>2</sup> 米/秒 <sup>2</sup>	<5,5	-	-	-	<5,5	-
17		N	25,0	24,2	28,9	26,9	28,9	34,8
18		l 升	0,42					
19			SAE 80W-90					

## Specifications

			MC 3C- 150/570 XT 230/1/50/13	MC 3C- 150/570 230/1/50/13	MC 3C- 170/820 400/3/50	MC 3C- 170/820 220-440/3/60	MC 3C- 170/820 XT 400/3/50	MC 3C- 170/820 XT 230-400/3/50
1			EU 欧盟	EU 欧盟	EU 欧盟	exp 其他	EU 欧盟	NO, BE 挪威、比 利时
2		V/ph/Hz	230/1/50	230/1/50	400/3/50	220/440/3/60	400/3/50	230/400/3/50
3		A	13	13	16	15	16	16
4		kW кВт	3,0	3,0	4,4	4,4	4,4	4,4
5		bar (MPa) Бар (МПа) 巴 (兆帕)	150 (15)	150 (15)	170 (17)	170 (17)	170 (17)	170 (17)
6		l/h л/час 升/小时	520	520	750	750	750	750
7		bar (MPa) Бар (МПа) 巴 (兆帕)	200 (20)	200 (20)	200 (20)	200 (20)	200 (20)	200 (20)"
8		l/h	570	570	820	820	820	820
9		°C (°F)	60, >40 max. 1 h. (140, >104 max. 1 h.)					
10		bar (MPa) Бар (МПа) 巴 (兆帕)	10 (1)					
11		m 米	0,5					
12		mm 毫米	382x382x1017					
13		kg кг	38	35,7	35,7	35,7	38	38
14	 (IEC 60335-2-69)	dB(A)+/-2 дБ(A)+/-2	78	78	81	81	81	81
15	 (IEC 60335-2-69)	dB(A)+/-2 дБ(A)+/-2	91	91	94	94	94	94
16a	 (ISO 5349 a <sub>h</sub> ) 	m/s <sup>2</sup> 米/秒 <sup>2</sup>	<2,5	<2,5	<2,5	<2,5	<2,5	<2,5
16b	 (ISO 5349 a <sub>h</sub> ) 	m/s <sup>2</sup> 米/秒 <sup>2</sup>	<5,5	-	-	-	<5,5	<5,5
17		N	25,0	25,0	38,4	38,4	38,4	38,4
18		l 升	0,42					
19			SAE 80W-90					

## Specifications

			MC 4M-140/620 230/1/50/13	MC 4M-140/620 230/1/50/13	MC 4M-100/770 230/1/50/13	MC 4M-140/620 XT 230/1/50/13	MC 4M-160/620 230/1/50/16
1			EU 欧盟	UK 英国	UK 英国	UK 英国	EU 欧盟
2		V/ph/Hz	230/1/50	230/1/50	230/1/50	230/1/50	230/1/50
3		A	13	13	13	13	16
4		kW кВт	2,9	2,9	2,8	2,9	3,0
5		bar (MPa) Бар (МПа) 巴 (兆帕)	140 (14)	140 (14)	100 (10)	140 (14)	160 (16)
6		l/h л/час 升/小时	580	580	720	580	560
7		bar (MPa) Бар (МПа) 巴 (兆帕)	200 (20)	200 (20)	150 (15)	200 (20)	200 (20)
8		l/h	620	620	770	620	620
9		°C (°F)	60, >40 max. 1 h. (140, >104 max. 1 h.)				
10		bar (MPa) Бар (МПа) 巴 (兆帕)	10 (1)				
11		m 米	0,5				
12		mm 毫米	382x382x1017				
13		kg кг	38,5	38,5	38,5	40,8	38,5
14	 (IEC 60335-2-69)	dB(A)+/-2 дБ(А)+/-2	73	73	73	73	73
15	 (IEC 60335-2-69)	dB(A)+/-2 дБ(А)+/-2	86	86	86	86	86
16a	 (ISO 5349 a <sub>h</sub> ) 	m/s <sup>2</sup> 米/秒 <sup>2</sup>	<2,5	<2,5	<2,5	<2,5	<2,5
16b	 (ISO 5349 a <sub>h</sub> ) 	m/s <sup>2</sup> 米/秒 <sup>2</sup>	-	-	-	<5,5	-
17		N	27,0	27,0	28,3	27,0	27,8
18		l 升	0,39				
19			SAE 80W-90				

## Specifications





			MC 4M-160/620 240/1/50/15	MC 4M-150/620 220/1/60/15	MC 4M-160/620 XT 230/1/50/16	MC 4M-180/740 400/3/50	MC 4M-180/740 220-440/3/60	MC 4M-160/720 200/3/50
1			AU	exp 其他	NO, BE 挪威、比 利时	EU 欧盟	exp 其他	JP 日本
2		V/ph/Hz	240/1/50	220/1/60	230/1/50	400/3/50	220/440/3/60	200/3/50
3		A	15	15	16	16	15	20
4		kW кВт	3,0	3,0	3,0	4,0	4,0	3,5
5		bar (MPa) Бар (МПа) 巴 (兆帕)	160 (16)	150 (15)	160 (16)	180 (18)	180 (18)	160 (16)
6		l/h л/час 升/小时	560	560	560	660	660	660
7		bar (MPa) Бар (МПа) 巴 (兆帕)	200 (20)	200 (20)	200 (20)	200 (20)	200 (20)	200 (20)
8		l/h	620	620	620	740	740	720
9		°C (°F)	60, >40 max. 1 h. (140, >104 max. 1 h.)					
10		bar (MPa) Бар (МПа) 巴 (兆帕)	10 (1)					
11		m 米	0,5					
12		mm 毫米	382x382x1017					
13		kg кг	38,5	38,5	40,8	40	40	38,5
14	 (IEC 60335-2-69)	dB(A)+/-2 дБ(A)+/-2	73	73	73	76	76	76
15	 (IEC 60335-2-69)	dB(A)+/-2 дБ(A)+/-2	86	86	86	89	89	89
16a	 (ISO 5349 a <sub>h</sub> ) 	m/s <sup>2</sup> 米/秒 <sup>2</sup>	<2,5	<2,5	<2,5	<2,5	<2,5	<2,5
16b	 (ISO 5349 a <sub>h</sub> ) 	m/s <sup>2</sup> 米/秒 <sup>2</sup>	-	-	<5,5	-	-	-
17		N	27,8	26,9	27,8	34,8	34,8	32,8
18		l 升	0,42	0,39				
19			SAE 80W-90					





## Specifications



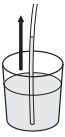

			MC 4M-160/720 200/3/60	"MC 4M-180/740 XT 400/3/50	MC 4M-180/740 XT 230-400/3/50	MC 4M-150/620 XT 220/1/60/15
1			JP 日本	EU 欧盟	NO, BE 挪威、比利时	exp 其他
2		V/ph/Hz	200/3/60	400/3/50	230/400/3/50	220/1/60
3		A	20	16	16	15
4		kW кВт	3,5	4,0	4,0	3,0
5		bar (MPa) Бар (МПа) 巴 (兆帕)	160 (16)	180 (18)	180 (18)	150 (15)
6		l/h л/час 升/小时	660	660	660	560
7		bar (MPa) Бар (МПа) 巴 (兆帕)	200 (20)	200 (20)	200 (20)	200 (20)
8		l/h	720	740	740	620
9		°C (°F)	60, >40 max. 1 h. (140, >104 max. 1 h.)			
10		bar (MPa) Бар (МПа) 巴 (兆帕)	10 (1)			
11		m 米	0,5			
12		mm 毫米	382x382x1017			
13		kg кг	38,5	42,3	42,3	40,8
14	 (IEC 60335-2-69)	dB(A)+/-2 дБ(A)+/-2	76	76	76	73
15	 (IEC 60335-2-69)	dB(A)+/-2 дБ(A)+/-2	89	89	89	86
16a	 (ISO 5349 a <sub>h</sub> ) 	m/s <sup>2</sup> 米/秒 <sup>2</sup>	<2,5	<2,5	<2,5	<2,5
16b	 (ISO 5349 a <sub>h</sub> ) 	m/s <sup>2</sup> 米/秒 <sup>2</sup>	-	<5,5	<5,5	<5,5
17		N	32,8	34,8	34,8	26,9
18		l 升	0,39			
19			SAE 80W-90			

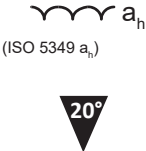
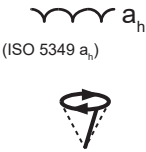

1			<b>EN:</b> Country variant. <b>DE:</b> Ländervarianten. <b>FR:</b> Selon le pays. <b>NL:</b> Nationale variant. <b>IT:</b> Variante per il Paese. <b>NO:</b> Variant i ulike land. <b>SV:</b> Landsvariant. <b>DA:</b> Landespecifik variant. <b>FI:</b> Maakohmainen vaihtelu. <b>ES:</b> Dependé del país. <b>PT:</b> Variante do país. <b>EL:</b> Έκδοση χώρας. <b>TR:</b> Ülke-deki model. <b>SL:</b> Jezikovna različica. <b>HR:</b> Ovisno o zemlji. <b>SK:</b> Vrsta ulja. <b>CS:</b> Varianta země. <b>PL:</b> Wersja dla kraju. <b>HU:</b> Országfüggő modellváltozatok. <b>RO:</b> Varianta țării. <b>BG:</b> Вариант за страната. <b>RU:</b> Региональное исполнение. <b>ET:</b> Riigi variant. <b>LV:</b> Valsts versija. <b>LT:</b> Šaliai skirtas variantas. <b>JA:</b> 国による相違。 <b>ZH:</b> 不同国家 <b>KO:</b> 국가별 모델. <b>TH:</b> แตกต่างกันไปตามประเทศ <b>MS:</b> Variasi negara.
2		V/ph/Hz	<b>EN:</b> Possible voltage. <b>DE:</b> Mögliche Spannung. <b>FR:</b> Tension autorisée. <b>NL:</b> Mogelijke spanning. <b>IT:</b> Possibile voltaggio. <b>NO:</b> Mulig spenning. <b>SV:</b> Möjlig spänning. <b>DA:</b> Spænding. <b>FI:</b> Mahdollinen jännite, V/vaiheluku/taajuus. <b>ES:</b> Tensión admitida. <b>PT:</b> Tensão possível. <b>EL:</b> Πιθανή τάση, V/ph/Frez. <b>TR:</b> Olası voltaj, V/Faz/Frekans. <b>SL:</b> Morebitna napetost. <b>HR:</b> Mogući napon. <b>SK:</b> Možné napätie. <b>CS:</b> Možné napětí. <b>PL:</b> Dopuszczalne napięcie, V/fazy/częst. <b>HU:</b> Tápészültség, V/fázis/frekv. <b>RO:</b> Tensiune posibilă, V/fază/Frecv. <b>BG:</b> Възможно напрежение. <b>RU:</b> Напряжение, В/φ./част. В/φ./Гц. <b>ET:</b> Võimalik pinge, V/faas/sagedus. <b>LV:</b> iespējamais spriegums. <b>LT:</b> Galima įtampa V / F / Frez. <b>JA:</b> 電圧。 <b>ZH:</b> 可能电压 ( V / ph / Fréz ) <b>KO:</b> 허용 전압, 볼트/상/헤르츠. <b>TH:</b> แรงดันไฟฟ้าที่สามารถใช้ได้ <b>MS:</b> Kemungkinan voltan.
3		A	<b>EN:</b> Fuse. <b>DE:</b> Sicherung. <b>FR:</b> Fusible. <b>NL:</b> Zekering. <b>IT:</b> Fusibile. <b>NO:</b> Sikring. <b>SV:</b> Säkring. <b>DA:</b> Sikring. <b>FI:</b> Sulake. <b>ES:</b> Fusible. <b>PT:</b> Fusível. <b>EL:</b> Ασφάλεια. <b>TR:</b> Sigorta. <b>SL:</b> Varovalka. <b>HR:</b> Osigurač. <b>SK:</b> Poistka. <b>CS:</b> Pojistka. <b>PL:</b> Bezpiecznik. <b>HU:</b> Biztosíték. <b>RO:</b> Siguranță. <b>BG:</b> Предпазител. <b>RU:</b> Предохранитель. <b>ET:</b> Kaitse. <b>LV:</b> Drošinātājs. <b>LT:</b> Saugiklis. <b>JA:</b> ヒューズ. <b>ZH:</b> 保险丝. <b>KO:</b> 퓨즈. <b>TH:</b> ฟิวส์. <b>MS:</b> Fius.
4		kW кВт	<b>EN:</b> Power rating. <b>DE:</b> Nennleistung. <b>FR:</b> Puissance nominale. <b>NL:</b> Nominiaal vermogen. <b>IT:</b> Corrente nominale. <b>NO:</b> Nominell effekt. <b>SV:</b> Märkeffekt. <b>DA:</b> Nominel effekt. <b>FI:</b> Tehontarve. <b>ES:</b> Potencia nominal. <b>PT:</b> Classificação de potência. <b>EL:</b> Ονομαστική ισχύς. <b>TR:</b> Elektrik değerleri. <b>SL:</b> Moč. <b>HR:</b> Oznaka napona. <b>SK:</b> Stanovenie výkonu. <b>CS:</b> Jmenovitý výkon. <b>PL:</b> Moc znamionowa. <b>HU:</b> Névleges teljesítmény. <b>RO:</b> Putere nominală. <b>BG:</b> Мощност. <b>RU:</b> Номинальная мощность кВт. <b>ET:</b> Vooluühik. <b>LV:</b> Nominālā jauda. <b>LT:</b> Galia. <b>JA:</b> 定格電力。 <b>ZH:</b> 额定功率. <b>KO:</b> 전원 등급. <b>TH:</b> อัตรากำลังไฟ. <b>MS:</b> Penarafan kuasa.
5		bar (MPa) Бар (МПа) 巴 (兆帕)	<b>EN:</b> Working pressure. <b>DE:</b> Arbeitsdruck. <b>FR:</b> Pression de service. <b>NL:</b> Werkdruk. <b>IT:</b> Pressione di esercizio. <b>NO:</b> Arbeidstrykk. <b>SV:</b> Arbetstryck. <b>DA:</b> Arbejdstryk. <b>FI:</b> Työpaine. <b>ES:</b> Presión de trabajo. <b>PT:</b> Pressão de trabalho. <b>EL:</b> Πίεση λειτουργίας. <b>TR:</b> Çalışma basıncı. <b>SL:</b> Delovni tlak. <b>HR:</b> Radni tlak. <b>SK:</b> Pracovný tlak. <b>CS:</b> Provozní tlak. <b>PL:</b> Ciśnienie robocze. <b>HU:</b> Üzemi nyomás. <b>RO:</b> Presiune de lucru. <b>BG:</b> Работно налягане. <b>RU:</b> Рабочее давление. <b>ET:</b> Töösurve. <b>LV:</b> Darba spiediens. <b>LT:</b> Darbinis slėgis. <b>JA:</b> 動作圧力。 <b>ZH:</b> 工作压力. <b>KO:</b> 작업 압력. <b>TH:</b> แรงดันขณะใช้งาน. <b>MS:</b> Tekanan kerja.
6		l/h л/час 升/小时	<b>EN:</b> Water flow. <b>DE:</b> Wasserdurchsatz. <b>FR:</b> Débit d'eau. <b>NL:</b> Waterdoorstroming. <b>IT:</b> Flusso dell'acqua. <b>NO:</b> Vanntilførsel. <b>SV:</b> Vattenflöde. <b>DA:</b> Vandmængde. <b>FI:</b> Vedenvirtaus. <b>ES:</b> Flujo de agua. <b>PT:</b> Fluxo de água. <b>EL:</b> Ροή νερού. <b>TR:</b> Su akışı. <b>SL:</b> Pretok vode. <b>HR:</b> Regulacija protoka vode. <b>SK:</b> Prietok vody. <b>CS:</b> Průtok vody. <b>PL:</b> Przepływ wody. <b>HU:</b> Vízfolyás. <b>RO:</b> Debit apă. <b>BG:</b> Воден поток. <b>RU:</b> Расход воды. <b>ET:</b> Veevool. <b>LV:</b> Ūdens plūsma. <b>LT:</b> Vandens srautas. <b>JA:</b> 流水. <b>ZH:</b> 水流量. <b>KO:</b> 급수량. <b>TH:</b> การไหลของน้ำ. <b>MS:</b> Aliran air.

7		bar (MPa) Бар (МПа) 巴 (兆帕)	<p><b>EN:</b> Max. water pressure. <b>DE:</b> Max Wasserdruck. <b>FR:</b> Pression d'eau maximale. <b>NL:</b> Max. waterdruk. <b>IT:</b> Max. pressione dell'acqua. <b>NO:</b> Maks. vanntrykk. <b>SV:</b> Max vattentryck. <b>DA:</b> Max. vandtryk. <b>FI:</b> Suurin vedenpaine. <b>ES:</b> Presión máxima de entrada del agua. <b>PT:</b> Pressão máxima de água. <b>EL:</b> Μέγ. πίεση νερού. <b>TR:</b> Maks. su basıncı. <b>SL:</b> Najv. vodni tlak. <b>HR:</b> Maksimalni tlak vode. <b>SK:</b> Maximálny tlak vody. <b>CS:</b> Max. tlak vody. <b>PL:</b> Maks. ciśnienie wody. <b>HU:</b> Max. víznyomás. <b>RO:</b> Presiune max. apă. <b>BG:</b> Макс. налягане на водата. <b>RU:</b> Макс. давление воды. <b>ET:</b> Max veesurve. <b>LV:</b> Maks. ūdens spiediens. <b>LT:</b> Maks. vandens slėgis. <b>JA:</b> 最高水圧 <b>ZH:</b> 最大水圧 <b>KO:</b> 최대 수압. <b>TH:</b> ความดันน้ำสูงสุด <b>MS:</b> Tekanan air maksimum.</p>
8		l/h	<p><b>EN:</b> Water flow <b>DE:</b> Wasserdurchsatz. <b>FR:</b> Débit d'eau. <b>NL:</b> Waterdoorstroming. <b>IT:</b> Flusso dell'acqua. <b>NO:</b> Vanntilførsel. <b>SV:</b> Vattenflöde. <b>DA:</b> Vandmængde. <b>FI:</b> Vedevirtaus. <b>ES:</b> Flujo de agua. <b>PT:</b> Fluxo de água. <b>EL:</b> Ποή νερού. <b>TR:</b> Su akışı. <b>SL:</b> Pretok vode. <b>HR:</b> Protok vode. <b>SK:</b> Prietok vody. <b>CS:</b> Průtok vody. <b>PL:</b> Przepływ wody. <b>HU:</b> Vízfolyás. <b>RO:</b> Debit apă. <b>BG:</b> Воден поток. <b>RU:</b> Расход воды. <b>ET:</b> Veevool. <b>LV:</b> Ūdens plūsma. <b>LT:</b> Vandens srautas. <b>JA:</b> 流水. <b>ZH:</b> 水流量 <b>KO:</b> 급수량. <b>TH:</b> การไหลของน้ำ <b>MS:</b> Aliran air.</p>
9		°C (°F)	<p><b>EN:</b> Max water inlet temperature, Intake-Pressure operation. <b>DE:</b> Max Wassereinlasstemperatur - Druckbetrieb. <b>FR:</b> Température max. de l'entrée d'eau en mode admission/pression. <b>NL:</b> Max. Waterinlaattemperatuur Inlaat-Tijdens. Bedrijf. <b>IT:</b> Temperatura max. alimentazione acqua Funzionamento a ingressopressione. <b>NO:</b> Maks. temperatur vanninntak, Inntakstrykk drift. <b>SV:</b> Max ingående vattentemperatur inlopps-tryckdrift. <b>DA:</b> Maks. vandtilgangstemperatur, tilgangstrykdrift. <b>FI:</b> Tuloveden suurin lämpötila, käytettäessä painepesurina. <b>ES:</b> Temperatura y presión máxima de entrada del agua. <b>PT:</b> Temperatura máxima de entrada de água, Funcionamento da pressão de entrada. <b>EL:</b> Μεγ. θερμοκρασία εισόδου νερού-λειτουργίας πίεσης. <b>TR:</b> Maks. su girişi sıcaklığı Emme-Basınçlı çalışma. <b>SL:</b> Najv. vstopna temperatura vode, vstopni tlak pri delovanju. <b>HR:</b> Maks. temperatura ulazne vode, tlak pri usisavanju. <b>SK:</b> Max. vstupná teplota vody, Prevádzka v nasávacom režime pod tlakom. <b>CS:</b> Max. teplota vody na vstupu, provozní sací tlak. <b>PL:</b> Maks. temperatura na dopływie wody z instalacji wodociągowej. <b>HU:</b> Max. bemenő vízhőmérséklet Szívónyomásos üzem. <b>RO:</b> Temperatura max. de admisie apă în cazul alimentării de la robinet. <b>BG:</b> Макс. температура на входящата вода – работа в режим на засмукване. <b>RU:</b> Макс. температура воды на входе (всасывание/подача под давлением). <b>ET:</b> Max vee sisselasketemperatuur Sissevoturõhk töö ajal. <b>LV:</b> Maks. ūdens ieplūdes temperatūra ieplūdes-spiediena darbībā. <b>LT:</b> Didžiausia vandens paėmimo temperatūra, veikimas esant įėjimo slėgiui. <b>JA:</b> 最高流入水温度、吸気圧力動作. <b>ZH:</b> 进水压力操作时的最高进水水温 <b>KO:</b> 최대 급수 온도 주입/압력 작동. <b>TH:</b> อุณหภูมิน้ำเข้าสูงสุด ความดันในการใช้งานบริเวณทางเข้า <b>MS:</b> Suhu maksimum air masuk, Kemasukan-Operasi tekanan.</p>
10		bar (MPa) Бар (МПа) 巴 (兆帕)	<p><b>EN:</b> Max. water inlet pressure. <b>DE:</b> Max. Wassereinlassdruck. <b>FR:</b> d'eau en mode admission/pression. <b>NL:</b> Max. waterinlaatdruk. <b>IT:</b> Pressione max. alimentazione acqua. <b>NO:</b> Maks. trykk vanninntak. <b>SV:</b> Max tryck för vatteninlopp. <b>DA:</b> Maks. Vandtilgangstryk. <b>FI:</b> Tuloveden suurin paine. <b>ES:</b> Presión máxima de entrada del agua. <b>PT:</b> Pressão máxima de entrada de água. <b>EL:</b> Μέγ. πίεση εισόδου νερού. <b>TR:</b> Maks. su girişi basıncı. <b>SL:</b> Najv. tlak dovoda vode. <b>HR:</b> Maks. tlak ulazne vode. <b>SK:</b> Max. vstupný tlak vody. <b>CS:</b> Max. tlak vody na vstupu. <b>PL:</b> Maks. ciśnienie na dopływie wody. <b>HU:</b> Max. bemenő nyomás. <b>RO:</b> Presiunea max. de alimentare cu apă. <b>BG:</b> Макс. налягане на входяща вода. <b>RU:</b> Макс. давление воды на входе. <b>ET:</b> Maks vee sissevoolusurve. <b>LV:</b> Maks. ūdens spiediens. <b>LT:</b> Didžiausias vandens paėmimo slėgis. <b>JA:</b> 最高流入水圧. <b>ZH:</b> 最大进水压力 <b>KO:</b> 최고 급수 압력. <b>TH:</b> ความดันน้ำเข้าสูงสุด <b>MS:</b> Tekanan maksimum air masuk.</p>

11		m 米	<p><b>EN:</b> Max dry suction height. <b>DE:</b> Max. Trockensaughöhe. <b>FR:</b> Hauteur d'aspiration à sec max. <b>NL:</b> Max. droge aanzuighoogte. <b>IT:</b> Altezza massima di aspirazione secco. <b>NO:</b> Maks. sugehøyde tørr. <b>SV:</b> Max torr-sugningshöjd. <b>DA:</b> Maks. sugehøjde, tør. <b>FI:</b> Suurin kuivaimukorkeus. <b>ES:</b> Altura máxima de succión en seco. <b>PT:</b> Altura de aspiração a seco máx. <b>EL:</b> Μέγ. ύψος αναρρόφησης. <b>TR:</b> Maks. Kuru emme yüksekliği. <b>SL:</b> Najv. višina suhega vsesavanja. <b>HR:</b> Maks. visina pri suhom usisavanju. <b>SK:</b> Max. suchá nasávacia výška. <b>CS:</b> Max. sací výška nasucho. <b>PL:</b> Maks. wysokość ssania na sucho. <b>HU:</b> Max. száraz szívómagasság. <b>RO:</b> Înălțime max. de aspirare în cazul alimentării cu apă dintr-un recipient. <b>BG:</b> Макс. височина на сухо засмукване. <b>RU:</b> Макс. высота всасывания. <b>ET:</b> Max kuivimu kõrgus. <b>LV:</b> Maks. sausās sūkšanas augstums. <b>LT:</b> Maksimalus sausas įsiurbimo aukštis. <b>JA:</b> 最大乾燥吸込高さ。 <b>ZH:</b> 最大干吸高度 米 <b>KO:</b> 최대 건조 흡입 높이. <b>TH:</b> ความสูงของท่อดูดแห้งสูงสุด <b>MS:</b> Ketinggian maksimum sedutan kering.</p>
12		mm 毫米	<p><b>EN:</b> Dimensions LxWxH. <b>DE:</b> Masse LxBxH. <b>FR:</b> Dimensions l x p x h. <b>NL:</b> Afmetingen LxBxH. <b>IT:</b> Dimensioni, lun. x larg. x alt. <b>NO:</b> Mål LxBxH. <b>SV:</b> Dimensioner LxBxH. <b>DA:</b> Mål LxBxH. <b>FI:</b> Mitat, PxLxK. <b>ES:</b> Dimensiones l x a x al. <b>PT:</b> Dimensões, C x L x A. <b>EL:</b> Διαστάσεις, Μ x Π x Υ. <b>TR:</b> Boyutlar, u x g x y. <b>SL:</b> Mere D x Š x V. <b>HR:</b> Dimenzije DxŠxV. <b>SK:</b> Rozmery D x Š x V. <b>CS:</b> Rozměry d x š x v. <b>PL:</b> Wymiary długość x szer. x wys. <b>HU:</b> Méretek H x Sz x M. <b>RO:</b> Dimensiuni. L x l x î. <b>BG:</b> Размери Д x Ш x В. <b>RU:</b> Размеры, Дл. x Шир. x Выс. <b>ET:</b> Mõõtmed p x l x k. <b>LV:</b> Izmēri G x P x A. <b>LT:</b> Matmenys (i x p x a). <b>JA:</b> 外形寸法長さx幅x高さ。 <b>ZH:</b> 尺寸 (长x宽x高) 毫米 <b>KO:</b> 크기(l x w x h). <b>TH:</b> ขนาด ยาว x กว้าง x สูง <b>MS:</b> Dimensi LxWxH.</p>
13		kg кг	<p><b>EN:</b> Weight. <b>DE:</b> Gewicht. <b>FR:</b> Poids du nettoyeur. <b>NL:</b> Gewicht van de hogedrukreiniger. <b>IT:</b> Peso dell'idropulitrice. <b>NO:</b> Vekt høytrykksvasker. <b>SV:</b> Maskinens vikt. <b>DA:</b> Vægt. <b>FI:</b> Pelkän painepesurin paino. <b>ES:</b> Peso del limpiador. <b>PT:</b> Peso da máquina de limpeza. <b>EL:</b> Βάρος μηχανήματος καθαρισμού. <b>TR:</b> Temizlik makinesinin yüksekliği. <b>SL:</b> Masa. <b>HR:</b> Težina. <b>SK:</b> Hmotnosť. <b>CS:</b> Hmotnost čisticího stroje. <b>PL:</b> Ciężar myjki. <b>HU:</b> Tisztítógép tömege. <b>RO:</b> Greutatea aparatului. <b>BG:</b> Тегло. <b>RU:</b> Вес моечной машины. <b>ET:</b> Pesuri kaal. <b>LV:</b> Tīrītāja svars. <b>LT:</b> Valymo įrenginio svoris. <b>JA:</b> 重量。 <b>ZH:</b> 清洗机重量 <b>KO:</b> 세척기 무게. <b>TH:</b> น้ำหนัก <b>MS:</b> Berat.</p>
14		dB(A) +/-2 дБ(A) +/-2	<p><b>EN:</b> Sound pressure level <math>L_{PA}</math>. <b>DE:</b> Schalldruckpegel <b>FR:</b> Niveau de pression acoustique <b>NL:</b> Geluidsdrukniveau <b>IT:</b> Livello pressione sonora <b>NO:</b> Lydtrykknivå <b>SV:</b> Ljudtrycksnivå <b>DA:</b> Lydtryksniveau <b>FI:</b> Äänenpainetaso <b>ES:</b> Nivel de presión sonora <b>PT:</b> Nível de pressão acústica <b>EL:</b> Επίπεδο πίεσης ήχου <b>TR:</b> Göre ses basıncı seviyesi <b>SL:</b> Raven zvočnega tlaka. <b>HR:</b> Razina zvučnog tlaka. <b>SK:</b> Hladina zvukového. <b>CS:</b> Hladina akustického tlaku <b>PL:</b> Poziom ciśnienia akustycznego <b>HU:</b> Hangnyomásszint <b>RO:</b> Nivel de presiune acustică <b>BG:</b> Ниво на звуково налягане <b>RU:</b> Уровень шума <b>ET:</b> Helisurve tase <b>LV:</b> Akustiskā spiediena līmenis <b>LT:</b> Garso slėgio lygis <b>JA:</b> 音圧レベル <b>ZH:</b> 声压级 <b>KO:</b> 음압 레벨 <b>TH:</b> ระดับความดันเสียง <b>MS:</b> Tahap tekanan bunyi</p>
15		dB(A) +/-2 дБ(A) +/-2	<p><b>EN:</b> Sound power level <math>L_{WA}</math>. <b>DE:</b> Schallleistungspegel <b>FR:</b> Niveau de puissance acoustique <b>NL:</b> Geluidsvermogeniveau <b>IT:</b> Livello potenza sonora <b>NO:</b> Lydeffektnivå <b>SV:</b> Ljudeffektnivå <b>DA:</b> Lydeffektniveau <b>FI:</b> Äänen tehotaso <b>ES:</b> Potencia acústica <b>PT:</b> Nível de potência acústica <b>EL:</b> Επίπεδο ισχύος ήχου <b>TR:</b> Göre ses basıncı seviyesi <b>SL:</b> Raven moči zvoka. <b>HR:</b> Razina jakosti. <b>SK:</b> Hladina zvukového výkonu. <b>CS:</b> Hladina akustického výkonu <b>PL:</b> Poziom mocy akustycznej <b>HU:</b> Hangteljesítmény szint <b>RO:</b> Nivelul de putere acustică <b>BG:</b> Ниво на звукова мощност <b>RU:</b> Уровень звуковой мощности <b>ET:</b> Helivõimsuse tase <b>LV:</b> Akustiskās jaudas līmenis <b>LT:</b> Garso galios lygis <b>JA:</b> 音響パワーレベル <b>ZH:</b> 声功率级 <b>KO:</b> 소음 레벨 <b>TH:</b> ระดับกำลังเสียง <b>MS:</b> Tahap kuasa bunyi</p>

16a	 (ISO 5349 a <sub>h</sub> )	$m/s^2$ 米/秒 <sup>2</sup>	<b>EN:</b> Vibration. <b>DE:</b> Vibrationen <b>FR:</b> Vibration <b>NL:</b> Vibratie <b>IT:</b> Vibrazioni <b>NO:</b> Vibrasjoner <b>SV:</b> Vibration <b>DA:</b> Vibration <b>FI:</b> Tärinäarvot <b>ES:</b> Vibración <b>PT:</b> Vibração <b>EL:</b> Δόνηση <b>TR:</b> Titreşimi <b>SL:</b> Vibracije. <b>HR:</b> Vibracije. <b>SK:</b> Vibrácie. <b>CS:</b> Vibrace <b>PL:</b> Drgania <b>HU:</b> Vibráció <b>RO:</b> Vibrații <b>BG:</b> Вибрации. <b>RU:</b> Вибрация <b>ET:</b> vibratsioon <b>LV:</b> vibrācija <b>LT:</b> Vibracijos <b>JA:</b> 振動。 <b>ZH:</b> 振动 <b>KO:</b> 진동 <b>TH:</b> แรงสั่นสะเทือน <b>MS:</b> Getaran.
16b	 (ISO 5349 a <sub>h</sub> )	$m/s^2$ 米/秒 <sup>2</sup>	<b>EN:</b> Vibration. <b>DE:</b> Vibrationen <b>FR:</b> Vibration <b>NL:</b> Vibratie <b>IT:</b> Vibrazioni <b>NO:</b> Vibrasjoner <b>SV:</b> Vibration <b>DA:</b> Vibration <b>FI:</b> Tärinäarvot <b>ES:</b> Vibración <b>PT:</b> Vibração <b>EL:</b> Δόνηση <b>TR:</b> Titreşimi <b>SL:</b> Vibracije. <b>HR:</b> Vibracije. <b>SK:</b> Vibrácie. <b>CS:</b> Vibrace <b>PL:</b> Drgania <b>HU:</b> Vibráció <b>RO:</b> Vibrații <b>BG:</b> Вибрации. <b>RU:</b> Вибрация <b>ET:</b> vibratsioon <b>LV:</b> vibrācija <b>LT:</b> Vibracijos <b>JA:</b> 振動。 <b>ZH:</b> 振动 <b>KO:</b> 진동 <b>TH:</b> แรงสั่นสะเทือน <b>MS:</b> Getaran.
17		N	<b>EN:</b> Recoil forces, lance. <b>DE:</b> Rückstoßkraft, Sprühhrohr <b>FR:</b> Forces de recul, lance <b>NL:</b> Terugslagkracht, lans <b>IT:</b> Forze di rinculo, lancia <b>NO:</b> Rekylkraft, lanse <b>SV:</b> Rekylkraft, spolrör <b>DA:</b> Rekylkraft, dyserør <b>FI:</b> Rekyylivoimat, suutin <b>ES:</b> Fuerzas de retroceso, lanza <b>PT:</b> Forças de retrocesso, lança <b>EL:</b> Δυνάμεις οπισθοδρόμησης, διάταξη ψεκασμού χη. <b>TR:</b> Sarmal kuvvetler, boru <b>SL:</b> Povratne sile, šoba. <b>HR:</b> Trzajne sile, mlaznica. <b>SK:</b> Spätný odraz, štandardná striekacia rúra. <b>CS:</b> Síly zpětného rázu, násadec <b>PL:</b> Siły odrzutu, lanca <b>HU:</b> Visszaható erő, szórócső <b>RO:</b> Forțe de recul, tija <b>BG:</b> Сили на откат, крайник. <b>RU:</b> Сила отдачи (распылитель). <b>ET:</b> Tagasilöögi jõud, otsik <b>LV:</b> Atsitiena spēks, smidzinātājs <b>LT:</b> Atatrankos jėga, antgalis <b>JA:</b> 反跳力、ランス。 <b>ZH:</b> 反冲力 ( 喷杆 ) <b>KO:</b> 반동력, 랜스 <b>TH:</b> แรงสะท้อนถอยหลัง, ปลายทอ <b>MS:</b> Kuasa sentakan, lans.
18		升	<b>EN:</b> Oil quantity. <b>DE:</b> Ölmenge. <b>FR:</b> Quantité d'huile. <b>NL:</b> Hoeveelheid olie. <b>IT:</b> Quantità olio. <b>NO:</b> Oljemengde. <b>SV:</b> Oljemängd. <b>DA:</b> Oliemængde. <b>FI:</b> Öljymäärä. <b>ES:</b> Cantidad de aceite. <b>PT:</b> Quantidade de óleo. <b>EL:</b> Ποσότητα λαδιού. <b>TR:</b> Yağ miktarı. <b>SL:</b> Količina olja. <b>HR:</b> Količina ulja. <b>SK:</b> Množstvo oleja. <b>CS:</b> Množství oleje. <b>PL:</b> Objętość oleju. <b>HU:</b> Olajmennyiség. <b>RO:</b> Cantitate de ulei. <b>BG:</b> Количество на маслото. <b>RU:</b> Количество масла. <b>ET:</b> Õli kogus. <b>LV:</b> Eļļas daudzums. <b>LT:</b> Tepalo kiekis. <b>JA:</b> オイル量。 <b>ZH:</b> 油量升 <b>KO:</b> 오일량. <b>TH:</b> ปริมาณน้ำมัน <b>MS:</b> Kuantiti minyak.
19			<b>EN:</b> Oil type. <b>DE:</b> Öltyp. <b>FR:</b> Type d'huile. <b>NL:</b> Olietype. <b>IT:</b> Tipo olio. <b>NO:</b> Oljetype. <b>SV:</b> Typ av olja. <b>DA:</b> Olietype. <b>FI:</b> Öljyn tyyppi. <b>ES:</b> Tipo de aceite. <b>PT:</b> Tipo de óleo. <b>EL:</b> Τύπος λαδιού. <b>TR:</b> Yağ tipi. <b>SL:</b> Vrsta olja. <b>HR:</b> Vrsta ulja. <b>SK:</b> Typ oleja. <b>CS:</b> Typ oleje. <b>PL:</b> Typ oleju. <b>HU:</b> Olaj típusa. <b>RO:</b> Tip de ulei. <b>BG:</b> Тип на маслото. <b>RU:</b> Тип масла. <b>ET:</b> Õli tüüp. <b>LV:</b> Eļļas tips. <b>LT:</b> Tepalo tipas. <b>JA:</b> オイルの種類。 <b>ZH:</b> 油型 <b>KO:</b> 오일 유형. <b>TH:</b> ประเภทน้ำมัน <b>MS:</b> Jenis minyak.

20

**EN:** Specifications and details are subject to change without prior notice. **DE:** Technische Daten und Details des Geräts können sich ohne vorherige Ankündigung ändern. **FR:** Ces spécifications et détails sont susceptibles d'être modifiés sans préavis. **NL:** Specificaties en details kunnen zonder voorafgaande waarschuwing worden gewijzigd. **IT:** Specifiche e dettagli sono soggetti a modifiche senza preavviso. **NO:** Spesifikasjonene og detaljene er gjenstand for endringer uten forutgående varsel. **SV:** Specifikationer och information kan ändras utan föregående meddelande. **DA:** Ret til ændringer i konstruktion og specifikationer forbeholdes. **FI:** Rakenteeseen ja teknisiin tietoihin voidaan tehdä muutoksia ilmoittamatta niistä ennalta. **ES:** Las especificaciones y los datos están sujetos a cambios sin previo aviso. **PT:** As especificações e os detalhes estão sujeitos a alterações sem aviso prévio. **EL:** Τα τεχνικά χαρακτηριστικά και οι λεπτομέρειες υπόκεινται σε αλλαγές χωρίς προηγούμενη ειδοποίηση. **TR:** Özellikler ve ayrıntılar, önceden haber verilmeden değiştirilebilir. **SL:** Tehnični podatki in podrobnosti se lahko spremenijo brez predhodnega obvestila. **HR:** Specifikacije i detalji mogu se mijenjati bez prethodne najave. **SK:** Špecifikácie a podrobnosti sa môžu meniť bez predchádzajúceho upozornenia. **CS:** Technické údaje a detaily mohou být změněny i bez předchozího upozornění. **PL:** Specyfikacje i parametry mogą zostać zmienione bez uprzedzenia. **HU:** A műszaki adatok és részletek előzetes értesítés nélkül megváltozhatnak. **RO:** Specificațiile și detaliile pot fi modificate fără înștiințare prealabilă. **BG:** Спецификациите и детайлите подлежат на промяна без предварително уведомление. **RU:** Технические характеристики и данные могут изменяться без предварительного извещения. **ET:** Tehnilisi kirjeldusi ja üksikasju võidakse muuta eelneva etteteatamiseta. **LV:** Specifikācijas un detaļas var tikt mainītas bez iepriekšēja paziņojuma. **LT:** Konstrukcija ir specifikacijos gali keistis be išankstinio įspėjimo. **JA:** 仕様および情報は事前通知無しに変更する場合があります。 **ZH:** 规格和详情如有变更，恕不另行通知。 **KO:** 사양 및 내용은 예고없이 변경될 수 있습니다. **TH:** ข้อกำหนดเฉพาะและรายละเอียดสามารถเปลี่ยนแปลงได้โดยไม่ต้องแจ้งให้ทราบล่วงหน้า **MS:** Spesifikasi dan butiran adalah tertakluk kepada perubahan tanpa notis terlebih dahulu.



# heupel Reinigungstechnik GmbH

Gottlieb Daimler Str. 6  
88214 Ravensburg

Tel: (049) 0751 - 35905-3  
Fax: (049) 0751 - 35905-59

email: [info@heupel-gmbh.de](mailto:info@heupel-gmbh.de)  
[www.heupel-gmbh.de](http://www.heupel-gmbh.de)

**Shop: [www.heupel-shop.de](http://www.heupel-shop.de)**

Heupel - Reinigungstechnik - Beratung, Verkauf, Service, alles aus einer Hand.

[www.nilfisk.com.at](http://www.nilfisk.com.at)

## AUSTRALIA

Nilfisk Pty Ltd  
Unit 1/13 Bessemer Street  
Blacktown NSW 2148  
Tel.: (+61) 2 98348100  
[www.nilfisk.com.au](http://www.nilfisk.com.au)

## AUSTRIA

Nilfisk GmbH  
Metzgerstrasse 68  
5101 Bergheim bei Salzburg  
Tel.: (+43) 662 456 400 90  
[www.nilfisk.at](http://www.nilfisk.at)

## BELGIUM

Nilfisk n.v.-s.a.  
Riverside Business Park  
Boulevard Internationalelaan 55  
Bâtiment C3/C4 Gebouw  
Bruxelles 1070  
Tel.: (+32) 24 67 60 50  
[www.nilfisk.be](http://www.nilfisk.be)

## BRAZIL

Nilfisk do Brasil  
Av. Eng. Luis Carlos Berrini, 550  
40 Andar, Sala 03  
SP - 04571-000 Sao Paulo  
Tel.: (+11) 3959-0300 / 3945-4744  
[www.nilfisk.com.br](http://www.nilfisk.com.br)

## CANADA

Nilfisk Canada Company  
240 Superior Boulevard  
Mississauga, Ontario L5T 2L2  
Tel.: (+1) 800-668-8400  
[www.nilfisk.ca](http://www.nilfisk.ca)

## CHILE

Nilfisk S.A. (Comercial KCS Ltda)  
Salar de Llamara 822  
8320000 Santiago  
Tel.: (+56) 2684 5000  
[www.nilfisk.cl](http://www.nilfisk.cl)

## CHINA

Nilfisk  
4189 Yindu Road  
Xinzhuang Industrial Park  
201108 Shanghai  
Tel.: (+86) 21 3323 2000  
[www.nilfisk.cn](http://www.nilfisk.cn)

## CZECH REPUBLIC

Nilfisk s.r.o.  
VGP Park Horní Počernice  
Do Čertous 1/2658  
193 00 Praha 9  
Tel.: (+420) 244 090 912  
[www.nilfisk.cz](http://www.nilfisk.cz)

## DENMARK

Nilfisk Danmark A/S  
Industrivej 1  
Hadsund, DK-9560  
Tel.: 72 18 21 20  
[www.nilfisk.dk](http://www.nilfisk.dk)

## FINLAND

Nilfisk Oy Ab  
Koskelontie 23 E  
02920 Espoo  
Tel.: (+358) 207 890 600  
[www.nilfisk.fi](http://www.nilfisk.fi)

## GREECE

Nilfisk A.E.  
Αναπαύσεως 29  
Κορωπί T.K. 194 00  
Tel.: (30) 210 9119 600  
[www.nilfisk.gr](http://www.nilfisk.gr)

## HOLLAND

Nilfisk B.V.  
Versterkerstraat 5  
1322 AN Almere  
Tel.: (+31) 036 5460760  
[www.nilfisk.nl](http://www.nilfisk.nl)

## HONG KONG

Nilfisk Ltd.  
2001 HK Worsted Mills  
Industrial Building  
31-39, Wo Tong Tsui St.  
Kwai Chung, N.T.  
Tel.: (+852) 2427 5951  
[www.nilfisk.com](http://www.nilfisk.com)

## HUNGARY

Nilfisk Kft.  
II. Rákóczi Ferenc út 10  
2310 Szigetszentmiklós-Lakihegy  
Tel.: (+36) 24 475 550  
[www.nilfisk.hu](http://www.nilfisk.hu)

## INDIA

Nilfisk India Limited  
Pramukh Plaza, 'B' Wing, 4th floor,  
Unit No. 403  
Cardinal Gracious Road, Chakala  
Andheri (East) Mumbai 400 099  
Tel.: (+91) 22 6118 8188  
[www.nilfisk.in](http://www.nilfisk.in)

## IRELAND

Nilfisk  
1 Stokes Place  
St. Stephen's Green  
Dublin 2  
Tel.: (+35) 3 12 94 38 38  
[www.nilfisk.ie](http://www.nilfisk.ie)

## ITALY

Nilfisk SpA  
Strada Comunale della Braglia, 18  
26862 Guardamiglio (LO)  
Tel.: (+39) (0) 377 414021  
[www.nilfisk.it](http://www.nilfisk.it)

## JAPAN

Nilfisk Inc.  
1-6-6 Kita-shinyokohama, Kouhoku-ku  
Yokohama, 223-0059  
Tel.: (+81) 45548 2571  
[www.nilfisk.com](http://www.nilfisk.com)

## MALAYSIA

Nilfisk Sdn Bhd  
Sd 33, Jalan KIP 10  
Taman Perindustrian KIP  
Sri Damansara  
52200 Kuala Lumpur  
Tel.: (60) 3603 627 43 120  
[www.nilfisk.com](http://www.nilfisk.com)

Website: [www.nilfisk.com](http://www.nilfisk.com)

## NORWAY

Nilfisk AS  
Bjørnerudveien 24  
1266 Oslo  
Tel.: (+47) 22 75 17 80  
[www.nilfisk.no](http://www.nilfisk.no)

## PERU

Nilfisk S.A.C.  
Calle Boulevard 162, Of. 703, Lima  
33- Perú  
Lima  
Tel.: (511) 435-6840  
[www.nilfisk.com](http://www.nilfisk.com)

## POLAND

Nilfisk Sp. Z.O.O.  
Millenium Logistic Park  
ul. 3 Maja 8, Bud. B4  
05-800 Pruszków  
Tel.: (+48) 22 738 3750  
[www.nilfisk.pl](http://www.nilfisk.pl)

## PORTUGAL

Nilfisk Lda.  
Sintra Business Park  
Zona Industrial Da Abrunheira  
Edificio 1, 1º A  
P2710-089 Sintra  
Tel.: (+351) 21 911 2670  
[www.nilfisk.pt](http://www.nilfisk.pt)

## RUSSIA

Nilfisk LLC  
Vyatskaya str. 27, bld. 7/1st  
127015 Moscow  
Tel.: (+7) 495 783 9602  
[www.nilfisk.ru](http://www.nilfisk.ru)

## SINGAPORE

Den-Sin  
22 Tuas Avenue 2  
639453 Singapore  
Tel.: (+65) 6268 1006  
[www.densin.com](http://www.densin.com)

## SLOVAKIA

Nilfisk s.r.o.  
Bancikovej 1/A  
SK-821 03 Bratislava  
Tel.: (+421) 910 222 928  
[www.nilfisk.sk](http://www.nilfisk.sk)

## SOUTH AFRICA

Nilfisk (Pty) Ltd  
Kimbult Office Park  
9 Zeiss Road  
Laser Park  
Honeydew  
Johannesburg  
Tel.: +27118014600  
[www.nilfisk.co.za](http://www.nilfisk.co.za)

## SOUTH KOREA

Nilfisk Korea  
#204 2F Seoulsup Kolon Digital  
Tower  
25 Seongsuil-ro 4-gil, Seongdong-gu  
Seoul.  
Tel.: (+ 82) 2 3474 4141  
[www.nilfisk.co.kr](http://www.nilfisk.co.kr)

## SWITZERLAND

Nilfisk AG  
Ringstrasse 19  
Kircheberg/Industri Stelz  
9500 Wil  
Tel.: (+41) 71 92 38 444  
[www.nilfisk.ch](http://www.nilfisk.ch)

## TAIWAN

Nilfisk Ltd  
Taiwan Branch (H.K.)  
No. 5, Wan Fang Road  
Taipei  
Tel.: (+88) 6227 00 22 68  
[www.nilfisk.tw](http://www.nilfisk.tw)

## THAILAND

Nilfisk Co. Ltd.  
89 Soi Chokechai-Ruammitr  
Viphavadee-Rangsit Road  
Ladyao, Jatuchak, Bangkok 10900  
Tel.: (+66) 2275 5630  
[www.nilfisk.co.th](http://www.nilfisk.co.th)

## TURKEY

Nilfisk A.S.  
Serifali Mh. Bayraktar Bulv. Sehiti  
Sk. No:7  
Ümraniye, 34775 Istanbul  
Tel.: +90 216 466 94 94  
[www.nilfisk.com.tr](http://www.nilfisk.com.tr)

## UNITED ARAB EMIRATES

Nilfisk Middle East Branch  
SAIF-Zone  
P.O. Box 122298  
Sharjah  
Tel.: (+971) (0) 655-78813  
[www.nilfisk.com](http://www.nilfisk.com)

## UNITED KINGDOM

Nilfisk Ltd.  
Nilfisk House, Bowerbank Way  
Gilwilly Industrial Estate, Penrith  
Cumbria CA11 9BQ  
Tel.: (+44) (0) 1768 868995  
[www.nilfisk.co.uk](http://www.nilfisk.co.uk)

## UNITED STATES

Nilfisk, Inc.  
9435 Winnetka Ave N,  
Brooklyn Park  
MN- 55445  
[www.nilfisk.com](http://www.nilfisk.com)

## VIETNAM

Nilfisk Vietnam  
No. 51 Doc Ngu Str.  
P. Vinh Phúc, Q.Ba Dinh  
Hanoi  
Tel.: (+84) 761 5642  
[www.nilfisk.com](http://www.nilfisk.com)

